

**EXHIBITORS TECHNICAL GUIDE**  
CIGRE 2024 August 25 > 30, 2024 Palais des Congrès, Paris  
[www.cigre-exhibition.com](http://www.cigre-exhibition.com)

**NEW !**

Opening of the Exhibition  
on **Sunday 25 August 2024**  
from **2:00 pm to 7:30 pm**

After the Opening Ceremony on Sunday,  
A Welcome Cocktail will be held  
on the 3 levels of the Exhibition floor  
OPEN TO ALL

PRO4EVENTS  
PERFORMANCE FOR YOUR EXHIBITIONS

Exhibition opening hours :

<b>Sunday 25 August :</b>	from 2 pm to 7:30 pm
<b>Monday 26 August :</b>	from 9 am to 6 pm
<b>Tuesday 27 August :</b>	from 9 am to 6 pm
<b>Wednesday 28 August :</b>	from 9 am to 6 pm
<b>Thursday 29 August :</b>	from 9 am to 6 pm
<b>Friday 30 August :</b>	from 9 am to 4:30 pm

Paris  
Session 2024



Document updated on March, 2024 - Informations are subject to change at any time

**WELCOME TO THE PALAIS DES CONGRES (VIPARIS)**

Description	Deadline	Pages
<b>CONTACTS</b> Pro4events Team		<b>6</b>
<b>VENUE</b> : Palais des Congrès, Porte Maillot (VIPARIS), Paris.		<b>7</b>
<b>HOTELS</b> : The last 3 days of the Session will be shared with the Paralympic Games in Paris (Paralympic games 28 August > 8 September 2024) Book your hotel > <a href="http://www.cigre2024-booking.com">http://www.cigre2024-booking.com</a> contact : <a href="mailto:cigre2024@mathez-viazur.com">cigre2024@mathez-viazur.com</a> , for any request	<b>Book your Hotel as soon as possible</b>	<b>8</b>
<b>GENERAL FLOOR PLAN</b> Presentation of the Session & services		<b>9 &gt; 11</b>
<b>OPENING HOURS</b> Opening of the Technical Exhibition on Sunday 25 August 2024 <b>from 2:00 pm to 7:30 pm</b>	<b>NEW ! Opening of the Technical Exhibition on Sunday 25 August at 2 pm</b>	<b>12</b>
<b>BADGES FOR EXHIBITORS</b> : a private mail has been sent to the Exhibition Manager with a dedicated link to register on line > if not received, send a mail to <a href="mailto:info@pro4events.com">info@pro4events.com</a> The platform to register is closing on 16 August, 2024  <b>BADGES FOR VISITORS</b> : Registration on line - see the prices page 13 – no refund is possible  <b>VISA REQUEST</b> : Complete the dedicated space directly on the badge registration form on line.	Registration is opened  Visa requests > fill in the form when you register for your badge	<b>13 - 14</b>
<b>MAIN SOCIAL EVENTS</b> during the Session NEW ! After the Opening Ceremony on Sunday 25 August a Welcome Cocktail will be held on the 3 levels of the exhibition floor (OPEN TO ALL)	<b>After the Opening Ceremony on Sunday, a Welcome Cocktail will be held on the 3 levels of the Exhibition floor</b>	<b>15</b>

**SPONSORSHIP OPPORTUNITIES – ROOM TO RENT**

<b>SPONSORSHIP OFFERS</b> for Exhibitors only  OFFERS & ORDER FORM at the end of the document	<b>BOOK NOW !</b> First come, First served Deadline 15 April	<b>16 &gt; 22</b>
<b>MEETING ROOMS TO RENT</b> for Exhibitors only First come, First served	Deadline 15 April	<b>23-24</b>

Non contractual document – information on this document is subject to changes without notice

## MANDATORY INFORMATION FOR YOUR STAND BUILDER & STAFF

Description	Deadline	Pages
<b>STAND LOCATION &amp; DIMENSIONS</b> on the Exhibition Floor plan After registration, each Exhibition Manager will receive a private mail with the location of the stand booked & dimensions from <a href="mailto:david.flandin@pro4events.com">david.flandin@pro4events.com</a>	<b>Important for your stand builder</b>	<b>25</b>
<b>STAND NUMBER</b> Check your stand number (subject to changes)	Check your stand number	<b>26</b>
<b>STAND FORMULE</b> Basic (=raw space) (possible to upgrade for a premium stand) or Formule + (shell) stand by CREATIFS (possible to upgrade for a premium stand) or Premium stand with GRAPHICS on walls, desk + storage room > <a href="#">CLICK HERE</a> by HUBER MESSEBAU	Check the stand package that you ordered	<b>27 &gt; 31</b>
<b>BASIC STAND</b> = raw space - we propose our STAND BUILDER Offer, if you want	See our stand builder offer for your raw space Deadline 15 April	<b>26</b>
<b>PILLARS</b> > cover the pillars with signage for high visibility	Deadline 15 April	<b>29</b>
<b>UPGRADE TO A PREMIUM STAND with GRAPHICS on walls &amp; desk + storage room</b> > <a href="#">CLICK HERE</a> + send a mail to <a href="mailto:info@pro4events.com">info@pro4events.com</a>	Choose to UPGRADE to a Premium stand with Graphics on Walls Deadline 30 June	<b>31</b>
<b>START-UP PAVILION (Level 1 – Neuilly side)</b>		<b>32</b>
<b>TECHNICAL RULES</b>	For your stand builder	<b>33 &gt; 37</b>
<b>BUILDING &amp; DISMANTLING TIMES</b>	For your stand builder	<b>38</b>
<b>TRANSPORT – CUSTOMS – HANDLING with ESI</b>	For your stand builder	<b>39</b>
<b>DELIVERY OF GOODS</b> <b>VIPARIS LOGIPASS PLATFORM</b> Registration of vehicles online prior to the delivery is mandatory (by VIPARIS)	For your stand builder	<b>40 &gt; 41</b>
<b>SMALL PARCELS</b> to send to the Venue		<b>40</b>
<b>GOODS LIFTS</b>	For your stand builder	<b>42</b>

## SERVICES INCLUDED IN THE EXHIBITORS' PACKAGE & FOR YOUR COMMUNICATION

<b>EXHIBITORS' PROFILE</b> printed in the Guidebook & displayed on the mobile App > Fill in the application form > <a href="#">CLICK HERE</a> OPEN TO EXHIBITORS & CO-EXHIBITORS (no extra cost)	New Deadline 04 April	<b>43</b>
<b>ADVERTISING BANNER FOR PROSPECTS</b>	Included in the package	<b>43</b>
<b>LEAVE PRESS KITS FOR JOURNALISTS</b> in the PRESS CENTER	Included in the package	<b>44</b>
<b>POST YOUR JOB OFFERS</b> on a board at the JOB CENTER	Included in the package	<b>44</b>
<b>BOOK A ROOM (limited to 1,5 hours during the week)</b> for your sales presentations, business meetings - First come, First served > <a href="mailto:sandrine.huchez@pro4events.com">sandrine.huchez@pro4events.com</a>	Deadline 15 April	<b>44</b>
<b>ACCESS TO THE OPENING CEREMONY</b> on Sunday 25 August at 3:30 pm OPEN TO ALL : Delegates, Visitors, Exhibitors	Included in the package	<b>44</b>
<b>NETWORKING</b> : A welcome cocktail will be held on the 3 levels of the exhibition just after the Opening Ceremony OPEN TO ALL	Included in the package	<b>44</b>

**SERVICES TO ORDER FOR YOUR STAND > MANDATORY TO ORDER POWER SUPPLY**

Description	Deadline	Pages
<p>&gt; <b>CHOOSE to order with the "READY TO EXHIBIT" PACKAGE managed by Pro4events</b>                      Electricity (mandatory to order) + Furniture + 1 TV (if needed)                      = 1 SUPPLIER &amp; 1 INVOICE</p> <p><b>CUSTOMIZED SERVICE</b> = management of your orders, quick answers to your technical questions &amp; requests, editing of your invoices and personalized feedback by Pro4events contact &gt; <a href="mailto:marion.caumont@pro4events.com">marion.caumont@pro4events.com</a></p>	<p>"Ready to Exhibit" package ALL IN ONE                      Deadline 15 April</p>	<p><b>45</b>                      order form at the end of this document</p>
<b>ELECTRICITY (it is mandatory to order power supply for the stand)</b>	Deadline 15 April	<b>46 &gt; 47</b>
FURNITURE	Deadline 15 April	<b>48</b>
TV LED SCREENS	Deadline 15 April	<b>48</b>
<b>STORAGE ROOM FOR Formule + (shell) stands</b> For premium stands, the storage room is already included	Deadline 15 April	<b>49</b>

**To increase visibility on the stand**

<b>RIGGING STRUCTURES</b> (suspension points) > order on Viparis store	Deadline 15 April	<b>50</b>
<b>COVER THE PILLARS</b> with advertising material > contact <a href="mailto:info@pro4events.com">info@pro4events.com</a>	Deadline 15 April	<b>29</b>

**More Services for the stand**

<b>WIFI</b> 2.4 Ghz is already included in the Exhibitors' package For customized or wired internet connections > order on Viparis store	Deadline 15 April	<b>51</b>
<b>OFFICE EQUIPMENT</b> : PRINTERS, COMPUTERS, VIDEO PROJECTOR, ELECTRICAL EQUIPMENT > order on Viparis store	Deadline 15 April	<b>51 &gt; 53</b>
<b>CLEANING</b> is already included in the exhibitors' package = cleaning after the building up + daily cleaning of your stand	Included in the package	<b>54</b>
<b>WASTE</b> removal after building and dismantling > order on Viparis store	Deadline 15 April	<b>54</b>
<b>CATERING</b> > order from RIEM BECKER	Deadline 15 April	<b>54</b>
<b>HOSTESS</b> > order from DECIBELLES	Deadline 15 April	<b>55</b>
<b>SECURITY GUARDS</b> > order from GUARDS EVENTS	Deadline 15 April	<b>55</b>
<b>FLORAL DECORATION</b> > order on Viparis store	Deadline 15 April	<b>56</b>
<b>BADGE READER</b> is already included in the exhibitors' package = 1 badge reader + 1 license to be downloaded on your smartphone It's possible to order more licenses > contact <a href="mailto:info@pro4events.com">info@pro4events.com</a>	Deadline 15 April	<b>57</b>
<b>TECHNICAL ASSISTANCE on site</b>	Services on site	<b>58</b>

**ORDER FORMS AT THE END OF THIS DOCUMENT**

For any question, contact [marion.caumont@pro4events.com](mailto:marion.caumont@pro4events.com) / [info@pro4events.com](mailto:info@pro4events.com)

Non contractual document – information on this document is subject to changes without notice



## GENERAL INFORMATION

Description	Deadline	Pages
SECURITY & SAFETY		<b>59</b>
INSURANCE	coming soon	<b>60</b>
VAT REFUND	coming soon	<b>60</b>

<b>TO ATTEND CONFERENCES REGISTER ON :</b>  > <a href="https://session.cigre.org/registration.html">https://session.cigre.org/registration.html</a> opening of registrations mid-February 2023 <b>Early bird until 15 May, 2024</b>  General programme on > <a href="https://session.cigre.org/programme/technical-programme.html">https://session.cigre.org/programme/technical-programme.html</a>	opening of Delegates registrations mid-February  <b>EARLY BIRD until 15 May</b>	<b>61</b>
--	---	-----------

<b>ORDER FORMS at the end of this document</b> For any question concerning technics, orders.. contact <a href="mailto:marion.caumont@pro4events.com">marion.caumont@pro4events.com</a> / <a href="mailto:info@pro4events.com">info@pro4events.com</a>	<b>Deadline 15 April</b>	<b>62 &gt; 77</b>
<b>PAYMENT</b> : Pro4events will issue an invoice after confirmation of the order & availabilities. Exhibitors have the possibility to pay by credit card	<b>Pro4events will issue an invoice</b>	<b>78</b>

### PRO4EVENTS for the organization of the CIGRE TECHNICAL EXHIBITION 2024

**Pro4events**

3-17 chemin du Lanfonnet  
74320 Sevrier - France  
Ph. + 33 [0]1 45 08 97 39

For the Technical Exhibition:  
[info@pro4events.com](mailto:info@pro4events.com)  
[www.cigre-exhibition.com](http://www.cigre-exhibition.com)

**CIGRE**

21 rue d'Artois  
75008 Paris - France  
Ph. +33 [0]1 53 89 12 90  
[www.cigre.org](http://www.cigre.org)

Document updated on March 30, 2024 - Informations are subject to change at any time

Pro4events, 3-17 chemin du Lanfonnet – 74320 Sevrier – France  
e-mail [info@pro4events.com](mailto:info@pro4events.com) / [www.cigre-exhibition.com](http://www.cigre-exhibition.com)

# CONTACTS

Paris  
Session 2024



**TECHNICAL EXHIBITION** > [www.cigre-exhibition.com](http://www.cigre-exhibition.com)

David Flandin, General Manager > [david.flandin@pro4events.com](mailto:david.flandin@pro4events.com)

Sandrine Huchez > [sandrine.huchez@pro4events.com](mailto:sandrine.huchez@pro4events.com)

Sponsorship Offers, Press, Job Center, orders...

Marion Caumont > [marion.caumont@pro4events.com](mailto:marion.caumont@pro4events.com)

Orders, technics, floor plans, rooms reservation ...

Adil ELHOUMANI > [stand-approval@pro4events.com](mailto:stand-approval@pro4events.com)

Approval of stand builders constructions

General mail : [info@pro4events.com](mailto:info@pro4events.com)

**CONFERENCE** > <https://session.cigre.org>

General programme on <https://session.cigre.org/programme/technical-programme.html>

**PRO4EVENTS**  
PERFORMANCE FOR YOUR EXHIBITIONS

## STAY CONNECTED during the Session

**APP CIGRE 2024 - OPENING IN AUGUST 2024**

Available on Google Play and Apple Store

Access to the General Programme, News & Events,

Detailed information on all the Exhibiting companies, Floor plan & Services

For Delegates only > follow the progress of the parallel discussions in the different Group Discussion Meeting Rooms, Download the Session Papers

### CIGRE TV

CIGRE TV will be broadcasted on line & in the Congress Centre each day of the Session,

Live interviews, latest news about the CIGRE Association, upcoming events...



#### Pro4events

3-17 chemin du Lanfonnet  
74320 Sevrier - France  
Ph. + 33 (0)1 45 08 97 39

For the Technical Exhibition:  
[info@pro4events.com](mailto:info@pro4events.com)  
[www.cigre-exhibition.com](http://www.cigre-exhibition.com)

#### CIGRE

21 rue d'Artois  
75008 Paris - France  
Ph. +33 (0)1 53 89 12 90  
[www.cigre.org](http://www.cigre.org)

# Venue : PALAIS DES CONGRÈS (Viparis)

Address : 2 Place de la Porte Maillot 75017 Paris – France [www.viparis.com](http://www.viparis.com)

Paris  
Session 2024



Access to the Congress Center (VIPARIS) > [GOOGLE MAP](#)

<https://www.viparis.com/en/our-venues/palais-des-congres-de-paris-en/access>

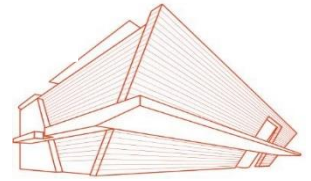
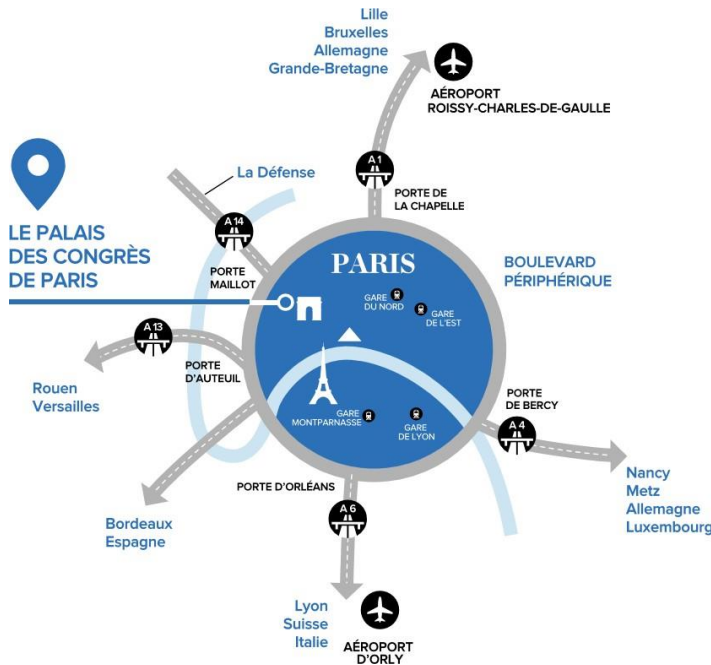

**METRO** Line 1 - Porte Maillot Station – exit 3

**RER C** – Neuilly – Porte Maillot Station

**RER E** – Porte Maillot Station (Gare EOLE in front of the main entrance of the Congress Center) > from or to Gare du nord

**BUS** Lines PC – 82 – 73 – 43 - 244

**NEW ! TRAMWAY Line T3b** - Porte Maillot Station [CLICK HERE](#)

*We invite you to buy your tickets online before your arrival on <https://www.iledefrance-mobilites.fr/en/tickets-fares>*

## BY PLANE

Around 40 minutes from Charles de Gaulles airport (CDG) around 30 minutes from Orly airport in normal conditions.

Due to the Olympic & Paralympic games, please check the access & necessary time to get to your hotel.

Shuttles for the airport Beauvais are on the parking boulevard Pershing (Neuilly side)

## BY CAR

From A1, A4, A6, A10, A15 : Take Paris direction, access via western section of the ring road, exit Porte des Ternes.

From A3, A13, A14 : Take Paris direction, access via southern section of the ring road, exit Porte Maillot.

**PARKING : INDIGO** [www.indigoneo.fr](http://www.indigoneo.fr) Tel. +33 (0)1 40 68 00 11 (the ceiling height is 1.9 m)

## TAXI RESERVATION

At the reception desks Palais des Congrès on level 0 (street level)

Reminder : The last 3 days of the Session will be shared with the Paralympic Games in Paris

Paralympic games : 28 August > 8 September 2024

More information about the access to the Palais des Congrès coming in April 2024

Document updated on March 30, 2024 - Informations are subject to change at any time

Pro4events, 3-17 chemin du Lanfonnet – 74320 Sevrier – France

e-mail [info@pro4events.com](mailto:info@pro4events.com) / [www.cigre-exhibition.com](http://www.cigre-exhibition.com)

# HOTELS

Paris  
Session 2024



Hotels have opened reservations for August 2024 >> **Don't wait to book !**

Even if the last three days of the Session will be shared with the Paralympic Games in Paris (Paralympic games 28 August > 8 September 2024), a great number of hotels located around the Congress Center have confirmed that rooms are available for the CIGRE session at reasonable prices. We have an example of an increase of 17,6 % compared to 2022.

If your usual hotel is charging unreasonable prices, have a look at CIGRE Hotel website :

CLICK on <http://www.cigre2024-booking.com>

To see the list of HOTELS available & book with VOYAGES C. MATHEZ Travel Agency

Email: [cigre2024@mathez-viazur.com](mailto:cigre2024@mathez-viazur.com) (if you need to book many rooms)



Document updated on March 30, 2024 - Informations are subject to change at any time

Pro4events, 3-17 chemin du Lanfonnet – 74320 Sevrier – France

e-mail [info@pro4events.com](mailto:info@pro4events.com) / [www.cigre-exhibition.com](http://www.cigre-exhibition.com)

# GENERAL FLOOR PLAN

Paris  
Session 2024



CIGRE 2024 General floor plan  
updated on January, 2024 (subject to changes at any time)

Find all the updated information on the mobile App, just before and during the Session

## LEVEL 0 street level

NEUILLY  
SIDE

PARIS  
SIDE

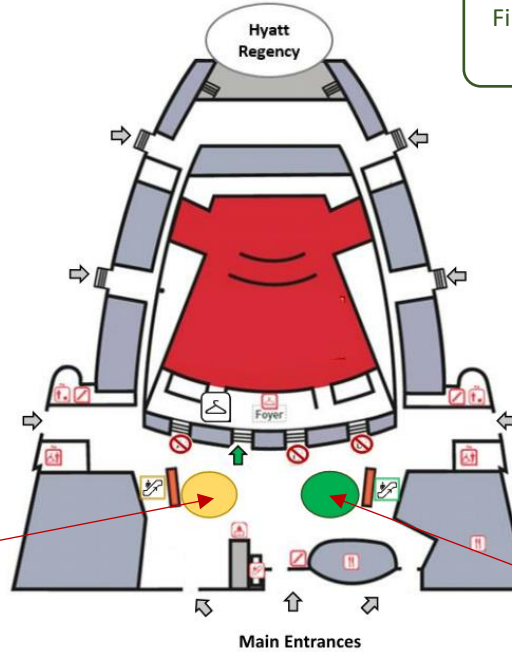

Welcome desk and access for Exhibitors, Visitors, Press (Neuilly side)

Welcome desk and access for Delegates, Companions, SC WG attendees (Paris side)

- Cloakroom
- Cloakroom entrance
- Entrance

### SESSION CIGRE 2024

Welcome desks on level 0 (open from Saturday 24 August, 9 am)

#### TECHNICAL EXHIBITION Levels 1, 2, 3

Start-up Pavilion Level 1 (Neuilly side)

**OPEN TO ALL**

#### CONFERENCE

Technical meetings Levels 2 & 3

Conference rooms : Amphi Bleu & Grand Amphi (Level 2), Havane & Bordeaux (Level 3)

Poster Sessions (Hall Ternes, Level 1)

Tutorials (Room Maillot, Level 2)

Workshops

**OPEN TO REGISTERED DELEGATES ONLY**

Document updated on March 30, 2024 - Informations are subject to change at any time

Pro4events, 3-17 chemin du Lanfonnet – 74320 Sevrier – France  
e-mail [info@pro4events.com](mailto:info@pro4events.com) / [www.cigre-exhibition.com](http://www.cigre-exhibition.com)



## LEVEL 1

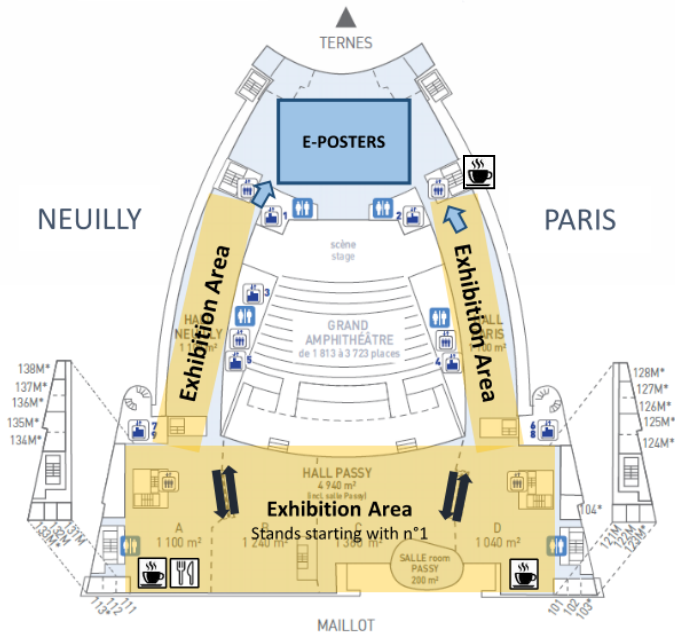

## LEVEL 2

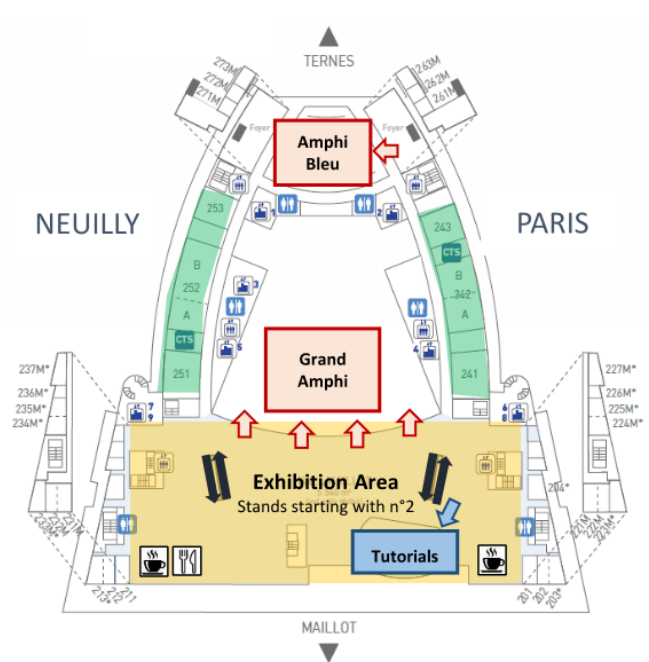

## LEVEL 3

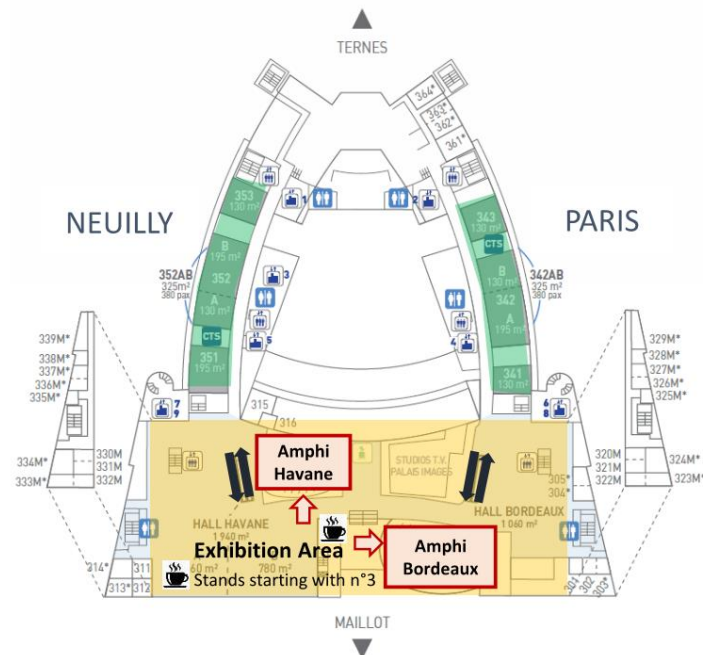

Paris  
Session 2024



Find all the updated information on the mobile App just before and during the Session

- E-Posters & Tutorials
- Conference Rooms
- Exhibition Area
- Meeting rooms
- Main room entrance
- Attendees arrival by stairs
- Coffee breaks areas
- Lunch bar

List of exhibitors CIGRE 2024 > [CLICK HERE](#)

After registration, each Exhibition manager receives a mail with the space location booked & dimensions  
if not received, please contact [info@pro4events.com](mailto:info@pro4events.com)

# SERVICES

## SERVICES

Welcome desks to collect the permanent badges - from Saturday, 9 am - Level 0

Cloakroom - from Saturday, 7 am - Level 0

Coffee breaks OPEN to ALL - every day from Monday > 9:30-11h00 am & 3:00-5:00 pm - Levels 1,2,3

Lunch bars (snacks, salads) - every day from Monday

Co-working areas

Medical Center - Level 3 - Room 335

Free Wifi & cleaning

**and more to come....**

**TECHNICAL SERVICES** for Exhibitors > Welcome desk to assist exhibitors with supply of power on the stand, delivery of furniture, badge reader pick up, shell stands, premium stands, delivery & handling, ...

Orders have to be sent to Pro4events before the event.

From Saturday (8 am) to Monday (2 pm) – Level 1

**EXHIBITORS OFFICE** : Press room – Job center - Rooms for exhibitors limited to 1hour during the week

Registration center for next exhibitions CIGRE CANADA 2024, CIGRE PARIS 2026

From Sunday (9 am), every day - Level 1 (location to be confirmed)

**CIGRE TV** : information, news, interviews to be displayed during the Session

**Marketing Station CIGRE**

**Publications CIGRE**

**Membership CIGRE**

**SC/WG welcome office (room 104)**

**Session information & lost and found**

**SPEAKING AREA** for exhibitors sponsoring the event > “The Experts Forum” on the exhibition floor - Level 3

**MEETING ROOMS** for exhibitors to rent, located on the exhibition floor (on Levels 1, 2, 3).

Contact : [info@pro4events.com](mailto:info@pro4events.com)

Paris  
Session 2024



Document updated on March 30, 2024 - Informations are subject to change at any time

Pro4events, 3-17 chemin du Lanfonnet – 74320 Sevrier – France

e-mail [info@pro4events.com](mailto:info@pro4events.com) / [www.cigre-exhibition.com](http://www.cigre-exhibition.com)

## OPENING HOURS

For professional Visitors, Congress Attendees, Exhibitors, Press, Media...

**NEW !** Opening of the Technical Exhibition on **SUNDAY 25 August 2024**

From 2:00 pm to 7:30 pm

**STANDS MUST BE READY AT 1:30 pm**

Exhibition opening hours :

**Sunday 25 August :** from 2 pm to 7:30 pm  
**Monday 26 August :** from 9 am to 6 pm  
**Tuesday 27 August :** from 9 am to 6 pm  
**Wednesday 28 August :** from 9 am to 6 pm  
**Thursday 29 August :** from 9 am to 6 pm  
**Friday 30 August :** from 9 am to 4:30 pm

Paris  
Session 2024



Exhibitors (only) can access 1 hour before the exhibition opening time and stay 30 minutes after the closing time.

Be aware that it will take longer to access the Session due to the traffic and security checks required at the entrance.

**NEW !** The same day, a **WELCOME COCKTAIL** will be held on the 3 levels of the exhibition floor from around 5:00 pm to 7:30 pm, just after the Opening Ceremony.

The Welcome cocktail is **OPEN TO ALL !** (Exhibitors, Visitors, Delegates)

Note that Exhibitors are welcomed to attend the Opening Ceremony meeting on Sunday at 3:30 pm  
Location : Grand Amphithéâtre ACCESS LEVEL 2

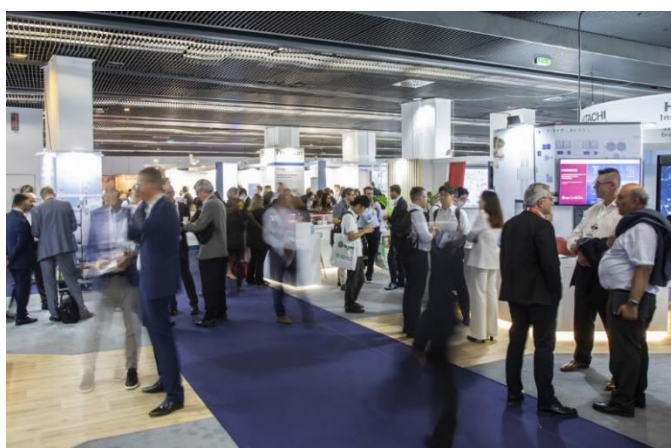

Document updated on March 30, 2024 - Informations are subject to change at any time

Pro4events, 3-17 chemin du Lanfonnet – 74320 Sevrier – France  
e-mail [info@pro4events.com](mailto:info@pro4events.com) / [www.cigre-exhibition.com](http://www.cigre-exhibition.com)

# BADGES

Mandatory for professional Visitors, Congress Attendees, Exhibitors, Press, Media...

Paris  
Session 2024



**Register for your e-badges on line BEFORE the event !**

**EXHIBITORS BADGES** : Please, note that from CIGRE 2024 & onwards, there is a **limited number of badges** allocated to each exhibiting company, **according to the surface area booked for the stand** (included in the exhibitors' package).

**The number of free badges allocated should cover the needs of the staff staying on the stand**  
**= 3 badges granted every 9 sqm booked**

- > exhibitors booking 9 sqm will be granted 3 free badges
- > exhibitors booking 18 sqm will be granted 6 free badges...

> **REGISTRATION** on <https://badgēcigre24.site.calypso-event.net/en/exhibitor-space/home.htm>

Exhibition managers have received a private mail with login and password to access the platform

> if not received, send a mail to [info@pro4events.com](mailto:info@pro4events.com)

**If you need more badges, send your request to [marion.caumont@pro4events.com](mailto:marion.caumont@pro4events.com) / [info@pro4events.com](mailto:info@pro4events.com) BEFORE 16 August 2024 (after that date, you will get ONLY visitors badges (fee= 300 euros)).**

Reminder : Exhibitors badges give access to the Opening Ceremony & Exhibition only.

**VISITORS BADGES** : Badges for clients, visitors who wish to access the Technical Exhibition

Visitors badges give access to the Opening Ceremony & Technical Exhibition, from 25 (from 2pm) to 30 August, 2024.

> **REGISTRATION** on <https://badgēcigre24.site.calypso-event.net/en/visitor/>

**EARLY BIRD price = 150 euros included VAT** if you register for your badge on line before 20 July, 2024

**REGULAR price = 300 euros included VAT** if you register your badge after 20 July, 2024 or on your arrival on site

Each badge is personal (it is not possible to give your badge to another visitor or to exchange it for a Delegate's badge).

**REFUND REQUESTS WILL NOT BE ACCEPTED**

**CONFERENCES** : If you wish to attend the Technical Exhibition and **CONFERENCES**, **please do not order a visitor's badge (no visitor's badge will be reimbursed)**. Instead, we invite you to order a **DELEGATE BADGE** directly by registering before the Session on > <https://session.cigre.org/registration.html>

**Badges are MANDATORY for ALL from Sunday 25 August, 2 pm**

**No badge required during the building & dismantling times (when the exhibition is closed)**

Document updated on March 30, 2024 - Informations are subject to change at any time

Pro4events, 3-17 chemin du Lanfonnet – 74320 Sevrier – France  
e-mail [info@pro4events.com](mailto:info@pro4events.com) / [www.cigre-exhibition.com](http://www.cigre-exhibition.com)

If you need and invitation letter to get a visa, please complete the dedicated space directly on the badge registration form on line.

Are you a CIGRE member ? \*  Yes  No

Visa requirements  Yes  No

VISA - Application for an invitation letter

Birth date \*

Passport : Place

Click on YES →

**EXHIBITORS** : Once registration is completed, you will be able to edit and download directly the visa letters from your private account.

**VISITORS** : Once registration is completed and **after payment for your order for a badge & validation**, you will be able to edit and download directly the visa letters from your private account.

## WELCOME DESKS TO COLLECT YOUR BADGE

Open from Saturday 24 August, 9 am  
LEVEL 0 (street level)

### COLLECT YOUR PERMANENT BADGE AS SOON AS YOU ARRIVE

At the Welcome desks, your e-badges will be exchanged for permanent badges.

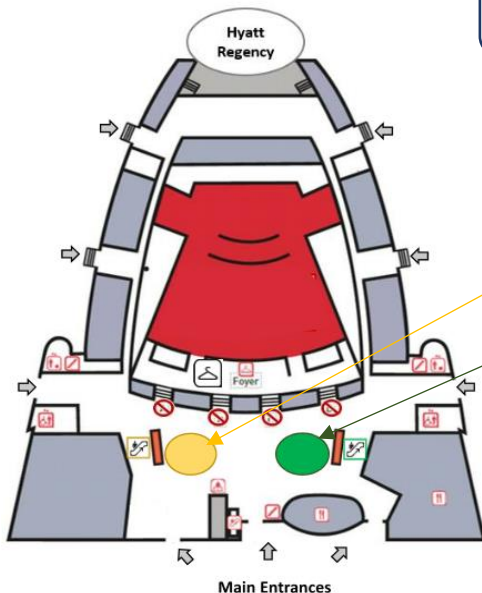

Welcome desk and access for Exhibitors, Visitors, Press (Neuilly side)

Welcome desk and access for Delegates, Companions, SC WG attendees (Paris side)

Cloakroom

Entrance

Badges must be worn at all times inside the Congress Center from Sunday 25 August, 2pm & during the Session



# MAIN SOCIAL EVENTS

Paris  
Session 2024



**Sunday 25 August, 2024**

**OPENING CEREMONY** starting at 3:30 pm  
Location : Grand Amphithéâtre – Entrance on LEVEL 2  
OPEN TO ALL (Delegates, Exhibitors, Visitors)

**WELCOME COCKTAIL** from around 5:00 to 7:30 pm, just after the Opening Ceremony  
Location : on the 3 levels of the Exhibition Floor  
OPEN TO ALL

**Thursday 29 August, 2024**

> Take the opportunity to become the **EXCLUSIVE SPONSOR** of the Welcome Cocktail  
see our **DIAMOND** offer next page or [CLICK HERE](#)  
Included in the **DIAMOND** package : your company logo on the lanyards distributed to 9000 attendees !

## **The CIGRE “Soirée”**

Location : Le Pavillon de Bercy - Musée des Arts Forains > <https://arts-forains.com/en>  
Access is strictly limited to the Delegates and their companions (one companion per Delegate)

> Take the opportunity to become the **EXCLUSIVE SPONSOR** of the CIGRE “Soirée”  
see our **PLATINUM** offer next page or [CLICK HERE](#)

## **And much more to NETWORK :**

Coffee breaks each mid-morning and each mid-afternoon  
Food & drinks areas  
Co-working areas

Just before & during the Session find the updated informations on the mobile App

*More information coming soon*

# SPONSORSHIP OPPORTUNITIES

For registered exhibitors only

TECHNICAL EXHIBITION August 25 > 30, 2024  
Palais des Congrès, Paris

Paris  
Session 2024



**New ! Become one of the  
exclusive Sponsors for the**

**Cocktail Reception** (25 August)

**NGN Event (Young Engineers)** (28 August)

**Cocktail Diner** (29 August)

**Women in Energy Event** (29 August)

And much more...

FIRST COME

FIRST SERVED

PRO4EVENTS  
PERFORMANCE FOR YOUR EXHIBITIONS

Paris  
Session 2024



Document updated on March 30, 2024 - Informations are subject to change at any time

Pro4events, 3-17 chemin du Lanfonnet – 74320 Sevrier – France

e-mail [info@pro4events.com](mailto:info@pro4events.com) / [www.cigre-exhibition.com](http://www.cigre-exhibition.com)

# Become an exclusive Sponsor

All sponsorship levels **DIAMOND, PLATINUM, GOLD 1 or GOLD 2** include the following:

- + 1 advertising page displayed on CIGRE TV
- + Your company logo displayed in ALL the coffee breaks and lunch areas

## DIAMOND (1 official Sponsor)

You can share this sponsorship  
with another sponsor (exhibitor)

**65 000 euros**  
(VAT excl.)

**OFFICIAL SPONSOR of the COCKTAIL RECEPTION on the 3 levels, inside the exhibition on Sunday 25 August** (around 5:00 pm to 7:30 pm, just after the Opening Ceremony) **+3 000 attendees**

Included in the DIAMOND package : your company logo printed on the lanyards distributed to 9000 attendees !

- 16 roll-ups displayed on 4 levels (Welcome area + 3 levels of the exhibition) on Sunday
- 1 catering banquet located in front of your booth
- Your company logo displayed each time the "Cocktail Reception" is listed : on the Guidebook / on the [CIGRE Session website](#) / on the event application / in the programme / on LinkedIn
- 1 advertising page (4 colors, inside page) in the Guidebook (8500 ex. printed)
- 2 interviews on CIGRE TV
- 1 month advertising on the [CIGRE Session website](#) (dates to be confirmed)
- 1 month banner on [e-cigre](#) (+110 000 views/year)
- 1 advertising video 30 seconds displayed in the conference rooms
- Your company logo on the lanyards (9000 attendees) > 1 logo CIGRE + 1 logo of your company
- 1 brochure / product in the conference bag (4000 delegates)
- 5 entrance tickets to access the Opening Ceremony & Cocktail Reception on Sunday

## PLATINUM (1 official Sponsor)

**42 500 euros**  
(VAT excl.)

**OFFICIAL SPONSOR of the CIGRE COCKTAIL DINER ("Soirée") at the Musée des Arts Forains on Thursday 29 August** (from 7:00 pm)  
**2 400 delegates**

- 2 roll-ups at the entrance of the Palais des Congrès (on Thursday)
- 6 roll-ups inside the Palais des Congrès (on Thursday)
- Your company logo displayed each time the "Cocktail diner" is listed : on the Guidebook / on the [CIGRE Session website](#) / on the event application / in the programme / on LinkedIn
- 1 advertising page (4 colors, inside page) in the Guidebook (8500 ex. printed)
- 1 interview on CIGRE TV
- 1 month advertising on the [CIGRE Session website](#) (dates to be confirmed)
- 1 month banner on [e-cigre](#) (+110 000 views/year)
- 5 companion tickets to access the CIGRE Cocktail diner on Thursday

First come, First served

**GOLD 1 (1 official Sponsor)**

**18 000 euros**  
(VAT excl.)

**OFFICIAL SPONSOR of the WOMEN IN ENERGY Event (WIE) at the Palais des Congrès  
on Thursday 29 August (11:30 am to 3:00 pm)  
250 attendees**

- 3 roll-ups at the entrance of the Palais des Congrès (on Thursday)
- 1 roll-up inside the meeting room (during the WIE Event)
- 5 to 10 minutes speech during the WIE Event
- Your company name displayed each time the “WIE” Event is listed : on the Guidebook / on the [CIGRE Session website](#) / on the event application / in the programme / on LinkedIn
- 1 advertising page (4 colors, inside page) in the Guidebook (8500 ex. printed)
- 1 month banner on [e-cigre](#) (+110 000 views/year)

**GOLD 2 (1 official Sponsor)**

**18 000 euros**  
(VAT excl.)

**OFFICIAL SPONSOR of the NGN Event (Young Engineers) at the Palais des Congrès  
on Wednesday 28 August (11:30 am to 3:00 pm)  
250 attendees**

- 3 roll-ups at the Palais des Congrès (on Wednesday)
- 1 roll up inside the meeting room (during the NGN Event)
- 5 to 10 minutes speech during the NGN Event
- Your company name displayed each time the “NGN” Event is listed : on the Guidebook / on the [CIGRE Session website](#) / on the event application / in the programme / on LinkedIn
- 1 interview on CIGRE TV
- 1 month advertising on the [CIGRE Session website](#) (dates to be confirmed)

**ORDER FORM > [CLICK HERE](#) & at the end of this document**

if you need a **customized package**, please contact us > [info@pro4events.com](mailto:info@pro4events.com)

[www.cigre-exhibition.com](http://www.cigre-exhibition.com)

PHOTO GALLERY CIGRE 2022  
> [CLICK HERE](#)

Document updated on January 20, 2024 - Informations are subject to change at any time

Pro4events, 3-17 chemin du Lanfonnet – 74320 Sevrier – France  
e-mail [info@pro4events.com](mailto:info@pro4events.com) / [www.cigre-exhibition.com](http://www.cigre-exhibition.com)

# More Sponsorship Opportunities

First come, First served

## 1/ SPEAKING OPPORTUNITY

A few slots remain available

In a dedicated conference open space **INSIDE THE EXHIBITION** : “The Experts Forum” on Level 3  
**25 mns speech** between 12:00 pm and 2:30 pm (from Monday to Friday) > see availabilities on the order form

**4 900 euros**  
1 slot of 25 mns  
(VAT excl.)

## 2/ INTERVIEW ON CIGRE TV

A few slots remain available

**CIGRE TV channel** will broadcast daily informative content during the Event (& in replay)  
**2 mns speech or interview** (date, time, location to be confirmed before the event) > see availabilities on the order form

**5 900 euros**  
1 slot of 2 mns  
(VAT excl.)

## 3/ DISPLAY YOUR VIDEO IN CONFERENCE ROOMS (Targeted audience : 3 500 Delegates)

Your advertising video (limited to 30 seconds) played alternately **with 5 other sponsors**  
In **CONFERENCE ROOMS** : Opening panel, GDM, Tutorials, Workshops..  
**During 1 day or during 5 days** (& in replay) for DELEGATES, **during conference breaks** (up to 8 breaks/day)

**6 500 euros**  
1 video played 1 day  
OR  
**14 900 euros**  
1 video played 5 days  
(VAT excl.)

## 4/ DISPLAY YOUR VIDEO INSIDE THE CONGRESS CENTER

Your advertising video (limited to 30 seconds) played alternately **with 1 other sponsor**  
**on 24 digital panels 75'**  
**HIGH VISIBILITY** > **during 9 days** (every minute) in the **New Welcome area on level 0**,  
in the corridors of the Hyatt Hotel, in front of the main amphitheater (where the Opening Ceremony takes place),...

**26 800 euros**  
1 video played  
on 24 digital panels  
during 9 days  
(VAT excl.)

## 5/ ADVERTISING PAGE IN THE GUIDEBOOK

Your advertising page printed in the Session Guidebook (=8500 printed catalogues)  
Back cover = 7 850 € inside front cover = 4 500 € inside back cover = 4 000 € Full page 4 colors = 1 600 €  
½ page = 1 100 €

**From 1 100**  
**to 7 850 euros**

## 6/ EXCLUSIVE BANNER ON THE CIGRE 2024 APP

**+11000 mobile app downloads** last Session 2022

**17 500 euros**  
exclusive sponsor  
(VAT excl.)

## 7/ OUTDOOR LOGO ON THE MAIN FACADE OF THE CONGRESS CENTER (EXCLUSIVE)

**HIGH VISIBILITY** > announcement of the CIGRE Session with the CIGRE logo + your logo  
on a panel 13m long x 10m long on the main façade of the Congress Center  
**Displayed during 9 days**

**SOLD**

**9 850 euros**  
exclusive sponsor  
(VAT excl.)



# Photo Gallery SPONSORSHIP OPPORTUNITIES

for registered exhibitors only

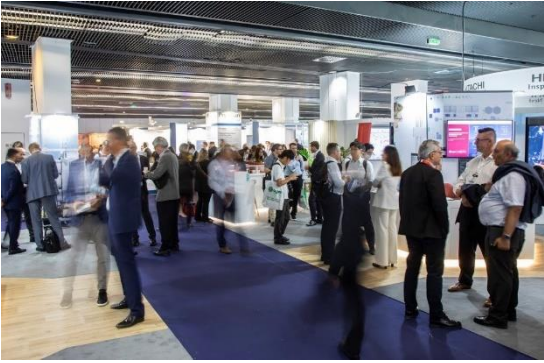

Pictures CIGRE 2022 non contractual



[www.cigre-exhibition.com](http://www.cigre-exhibition.com)



Speaking opportunity  
inside the Exhibition

First come, First served



Interview  
on CIGRE TV

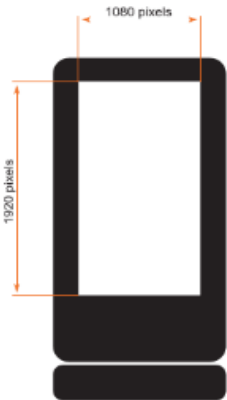

Display your advertising video inside the Congress Center (on 24 digital panels - Level 0)  
**New ! The Welcome area will be on level 0**  
**HIGH VISIBILITY !**



Display your advertising video in Conference rooms  
**Targeted audience = 3 500 Delegates**



Pictures CIGRE 2022 non contractual

Paris  
**Session 2024**



Your advertising page in the Guide Book  
 (8 500 catalogues printed)

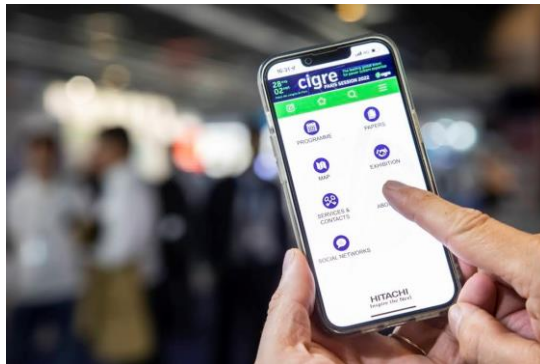

**Exclusive** advertising banner on the  
 official CIGRE app

## Technical Data SPONSORSHIP OPPORTUNITIES for registered exhibitors only

First come, First served

**TO BE SENT TO [info@pro4events.com](mailto:info@pro4events.com) :**

**YOUR COMPANY LOGO** if requested > JPEG format HD

It is agreed that Pro4events can display the logo on screens and documents during the Session and in replay.

### **DISPLAY YOUR VIDEO IN CONFERENCE ROOMS (offer 3)**

Provide 1 video **Format MP4** HIGH DEFINITION > Your video will be played on a big screen

Limited to 30 seconds – insert the CIGRE logo inside your video

+ send a web link to your video to [sandrine.huchez@pro4events.com](mailto:sandrine.huchez@pro4events.com) / [info@pro4events.com](mailto:info@pro4events.com)

### **DISPLAY YOUR VIDEO INSIDE THE CONGRESS CENTER (offer 4)**

Provide 1 video High Definition resolution 1080 pixels wide by 1920 pixels

to be sent to [b.morel@liote.fr](mailto:b.morel@liote.fr) & [programmation\\_digitale@clearchannel.fr](mailto:programmation_digitale@clearchannel.fr) (copy to [info@pro4events.com](mailto:info@pro4events.com))

Limited to 30 seconds - insert the CIGRE logo inside your video

Regarding the French law, all the English texts have to be translated into French, to be inserted with an Asterix \* on the side or at the end of the page, in small letters.

[CLICK HERE](#) to see the specifications or contact us : [sandrine.huchez@pro4events.com](mailto:sandrine.huchez@pro4events.com) / [info@pro4events.com](mailto:info@pro4events.com)

### **ADVERTISING PAGE IN THE GUIDEBOOK (offer 5)**

Provide a PDF High Definition

1 page = L 150 x H 210 mm

½ page = L 140 x H 97.5 mm

+ 7mm for the inner margin + 5mm for cut lines and bleed

[CLICK HERE](#) for the dimensions of the inside pages & [CLICK HERE](#) for the dimensions of the cover

### **EXCLUSIVE BANNER ON THE CIGRE 2024 APP (offer 6)**

Provide a banner with your logo 1125 x 200 (max 170 kilo-octets) or 1516 x 210 (max 220 kilo octets)

### **OUTDOOR LOGO ON THE MAIN FAÇADE OF THE CONGRESS CENTER (offer 7) – SOLD -**

1 logo CIGRE + your logo

size of your logo 2.5m x 2.5m

on a panel 13m long x 10m long displayed on the main facade of the Congress Center

**DEADLINE to order : April 15, 2024**

ORDER FORM at the end of this document

Paris  
Session 2024



Document updated on March 30, 2024 - Informations are subject to change at any time

Pro4events, 3-17 chemin du Lanfonnet – 74320 Sevrier – France

e-mail [info@pro4events.com](mailto:info@pro4events.com) / [www.cigre-exhibition.com](http://www.cigre-exhibition.com)

# MEETING ROOMS FOR RENTAL

Paris  
Session 2024



“ready to use” (for exhibitors only)

ALL equipped  
ON THE EXHIBITION FLOOR (on levels 1, 2, 3)

Rent a private room to welcome clients, guests during CIGRE Session

First come, First served

DURING 5 DAYS : from Monday 26 to Friday 30 August

RENTAL HOURS : from 9 am to 6 pm (closing at 4:30 pm on Friday)

## PACKAGE 1

FOR a 12 sqm room welcoming up to 6 persons

= 4 000 euros for 5 days (excluding VAT)

Including :

- 4 walls
- 1 door & lock
- 1 window with your LOGO on it
- Carpet on floor
- Power supply & sockets
- Lights
- Wireless HD Wifi
- + Basic chairs (up to 6 chairs)
- + Tables (if meeting room style) or 1 desk (if theatre style)
- + 1 TV screen with HDMI cable

Choose between  
Meeting room style



RÉUNION  
MEETING

OR



THÉÂTRE  
THEATRE

Theatre room style

Send your LOGO to [info@pro4events.com](mailto:info@pro4events.com)  
JPEG HD definition



## PACKAGE 2

FOR a 24 sqm room  
welcoming up to 10 persons (meeting room style)  
OR welcoming up to 14 persons (theatre room style)

= 6 500 euros for 5 days (excluding VAT)

Including :

4 walls

1 door & lock

1 window with your LOGO on it

Carpet on floor

Power supply & sockets

Lights

Wireless HD Wifi

+ Basic chairs (up to 10 or 14 chairs)

+ Tables (if meeting room style) or 1 desk (if theatre style)

+ 1 TV screen with HDMI cable

## LOCATION ON THE EXHIBITION FLOOR

ORDER FORM at the end of this document

### Additional services must be ordered separately :

CATERING for food & beverage > contact RIEM BECKER

Sebastien Manes > [sebastien.manes@riembecker.fr](mailto:sebastien.manes@riembecker.fr) (+ 33 (0)1 86 64 14 46)

More information & order form page 54 – send a copy of your mail to [info@pro4events.com](mailto:info@pro4events.com)

FRIDGE, COFFEE MACHINE, WATER FOUNTAIN

more FURNITURE (chairs, tables, sofas...) > see the catalogue on <https://camerus.com/en/salon/cigre-2024/>

+ complete the order form at the end of this document - More information page 48

more TV SCREENS > complete the order form at the end of this document

More information on page 48

OFFICE EQUIPMENT – INTERNET LAN – PRIVATE WIFI – MICROPHONES

FLORAL DECORATION > [order directly on VIPARIS STORE https://www.viparisstore.com/en/#](https://www.viparisstore.com/en/#) / copy to [info@pro4events.com](mailto:info@pro4events.com)

HOSTESS > contact DECIBELLES

Ana Calpe del Arco > [ana@deci-belles.com](mailto:ana@deci-belles.com) - Tel. +33 (0)1 40 60 11 28

More information & order form page 55 – send a copy of your mail to [info@pro4events.com](mailto:info@pro4events.com)

Orders are non-cancelable and non-refundable and must be placed before 30 April 2024

For any question or specific request (for a bigger room), please contact [info@pro4events.com](mailto:info@pro4events.com)

Document updated on March 30, 2024 - Informations are subject to change at any time

Pro4events, 3-17 chemin du Lanfonnet – 74320 Sevrier – France

e-mail [info@pro4events.com](mailto:info@pro4events.com) / [www.cigre-exhibition.com](http://www.cigre-exhibition.com)



## Stand location & dimensions

After registration, each Exhibition Manager receives a private mail with the location of the stand booked and dimensions. If not received or if any question, please contact : [david.flandin@pro4events.com](mailto:david.flandin@pro4events.com)

Please, note :

> the size of a few locations (not all locations are concerned) may change slightly after a last SECURITY CHECK of the floor plan (with a difference of + or – 20% as compared to the surface initially booked)

> the position of the pillars is not accurate (+/- 30 cm)

You can take advantage of the pillars on the stand to increase visibility > see our post cladding offer > contact : [info@pro4events.com](mailto:info@pro4events.com)

### **ALL STAND PROJECT**

or additional decoration to the shell-stand (Formule + or Premium)

**are to be sent to Pro4events for approval BEFORE May 30, 2024**

Send a mail to : [stand-approval@pro4events.com](mailto:stand-approval@pro4events.com) / copy to [info@pro4events.com](mailto:info@pro4events.com)

Stand builders must ask the Exhibition Manager to validate the drawings before any submission to Pro4events.

Pro4events hereby reserves the right to modify any stand that fails to comply with the present rules and regulations by any company of its choice and at the sole expense of the exhibitor.

Paris  
Session 2024



Document updated on March 30, 2024 - Informations are subject to change at any time

Pro4events, 3-17 chemin du Lanfonnet – 74320 Sevrier – France

e-mail [info@pro4events.com](mailto:info@pro4events.com) / [www.cigre-exhibition.com](http://www.cigre-exhibition.com)

List of exhibitors & stand numbers > [CLICK HERE](#)

Subject to changes

LEVEL 1 : stand number starts with number S1

LEVEL 2 : stand number starts with number S2

LEVEL 3 : stand number starts with number S3

## **Exhibition space is the largest ever !**

Demand for stands is much higher for the 2024 edition than in previous Sessions

!

### **2 NEW exhibition spaces on LEVEL 1**

have been opened to accommodate all the registered exhibitors

## Stand formule : Basic / Shell / Premium stand

### BASIC STAND = Raw space

Paris  
Session 2024



#### Services included in the package :

- Raw space
- High speed Wifi
- General security
- Basic Insurance
- Daily cleaning of your space
- Advertising e-banner for visitors
- Guide book (=catalogue) & mobile app registration

#### + Pack services :

- Exhibition staff badges (limited number of free badges)
- Badge reader : (1) one electronic badge reader provided for each booth + 1 license to be downloaded on a smartphone.

**POWER SUPPLY is not included (mandatory to order)** > easy booking with the "Ready to Exhibit" Package including Electricity + Furniture (+ or) TV Led screen, managed by Pro4events > see the order form at the end of this document.



If you booked RAW SPACE (Basic Stand)  
see one offer from the stand builder STAND 2B  
> [www.stand2b.com](http://www.stand2b.com)

TAILOR BUILT STANDS  
ECO MODULAR PANELS - ISO 20121 certification

LED TILES FOR BUILDING VIDEO WALLS



#### Contact :

**Alexandre Prost** > [a.prost@stand2b.fr](mailto:a.prost@stand2b.fr)

Tel : +33 (0)6 46 86 31 28

**Solène ROMAN** > [s.roman@stand2b.fr](mailto:s.roman@stand2b.fr)

Tel : +33 (0)7 57 76 90 76

COPY to [info@pro4events.com](mailto:info@pro4events.com)

The allocated space might be + or - 20 % smaller than the space ordered after the final security check  
The position of the pillars is not accurate (+/- 30 cm)

## SHELL STAND Formule +



Example of a 9 sqm stand  
Non contractual pictures



Example of premium stands at CIGRE 2022  
Furniture is not included in the package

Stand builder : CREATIFS

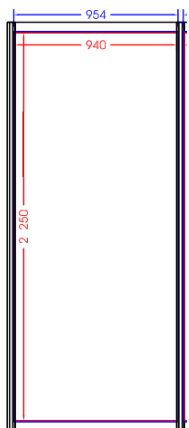

> Inside dimensions of 1 panel  
HT 2250 x L 940 mm

### Services included in the package :

- = Basic stand
- + Partitioning and division walls (grey laminate)
- + Carpet (grey)
- + One sign per open side
- + 3 spotlights on rail / 9 sqm

### OPTIONS for FORMULE + (shell stands) :

#### >STORAGE ROOM

- Storage room 1,00 m x 1,00 m = 210 euros
- Storage room 1,00 m x 2,00 m = 250 euros - closed with a key
- Order form at the end of this document

### + Exhibitors have to order power supply for the stand

- + Furniture + (or) TV Led screen(s) *if needed*

Choose our "Ready to Exhibit Package" ALL IN ONE  
managed by Pro4events

Order form at the end of this document Page 63



Paris  
Session 2024



Document updated on March 30, 2024 - Informations are subject to change at any time

Pro4events, 3-17 chemin du Lanfonnet – 74320 Sevrier – France  
e-mail [info@pro4events.com](mailto:info@pro4events.com) / [www.cigre-exhibition.com](http://www.cigre-exhibition.com)

# Pillars on the Stand



Non contractual picture

Use pillars as  
**EYE CATCHERS**  
Cover the pillar on the stand  
with or without signage

Paris  
Session 2024

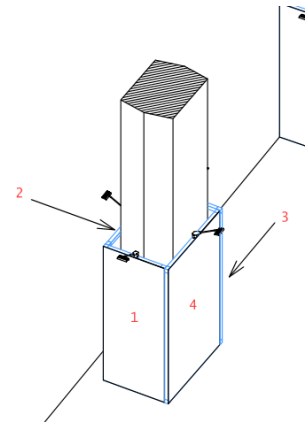

## On MELAMINE

**MODULAR PARTITION HEIGHT 2.40M**  
MELAMINE PANEL - ALUMINIUM STRUCTURE

**115 €** without signage  
**395 €** with signage

Detail of signage :  
PRINTED PVC PANEL TO REPLACE THE PARTITION  
Width 954 mm x Height 2254 mm  
1 unit

**HALL PASSY - level 1**      **HALL NEUILLY - level 1**

Designed by CREATIFS > send your logo & advertising image to [cigre.exposants@creatifs.fr](mailto:cigre.exposants@creatifs.fr) / copy to [info@pro4events.com](mailto:info@pro4events.com)

## On WOOD

**WOOD PARTITION HEIGHT 2.50M**  
WOOD PARTITION THICKNESS 60mm COVERED IN COTTON

**263 €** without signage  
**543 €** with signage

Detail of signage :  
PRINTED PVC PANEL FIXED AGAINST PARTITION  
Width 1000 mm x Height 2500 mm  
1 unit

**HALL PASSY - level 1**      **HALL NEUILLY - level 1**

**ORDER FORM** at the end of this document



# PREMIUM STAND

Personalize your stand at your image

**Stand builder : HUBER MESSEBAU**  
 contact : Diego Alemanni  
 d.alemanni@huber-messebau.ch



Non contractual pictures



Example of premium stands at CIGRE 2022

This stand image is only an example. Your stand could have a completely different shape

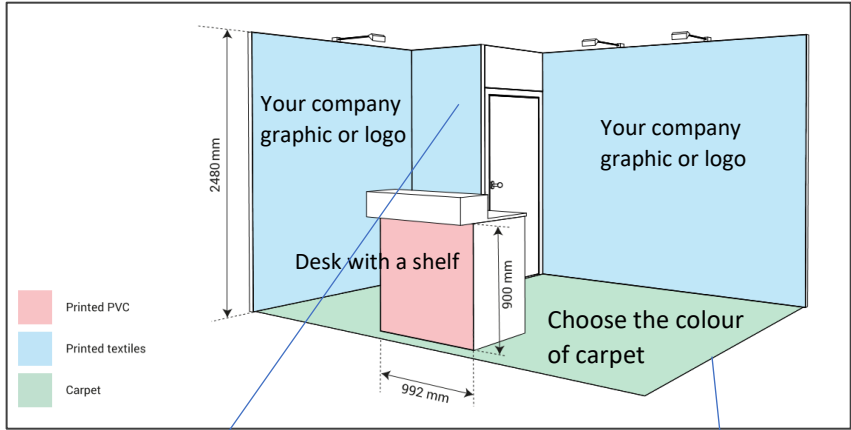

- Services included in the package :**
- = Basic stand
  - + Personalized choice of colors for walls (textile) and carpet
  - + 1 welcome desk with a shelf
  - + Logos and company graphics on the welcome desk and on the walls
  - + Storage room (1 sqm up to 15 sqm – 2 sqm for larger stand) with key
  - + 1 spotlight LED 30W / 3 sqm

**HOW TO PREPARE GRAPHIC FILES**  
 > [CLICK HERE](#)

Graphic designer : cad@huber-messebau.ch



**Options for PREMIUM stands :**  
 > 3 shelves & Wardrobe = 64 euros  
 Order form at the end of this document

**+ Exhibitors have to order power supply for the stand**

+ Furniture + (or) TV Led screen(s) *if needed*

**Choose our "Ready to Exhibit Package" ALL IN ONE managed by Pro4events**  
 Order form at the end of this document Page 63





**Shell > premium stand    Basic > premium stand**  
**> upgrade TO a premium stand**

**SHELL STAND**

OR



**PREMIUM STAND**

**Personalize your stand at your image**

What is included = Basic stand package

+

**Walls in grey laminate**

**Carpet in grey**



3 spotlights on rail / 9 sqm

+ One sign per open side & a floor marker with your stand number

**Walls with your company graphics / logo**  
printed on textile

**Carpet** > choose among 9 colours



**+ A welcome desk with a shelf**  
with your graphics / logo printed on pvc



**+ A storage room** closed with a key  
1 sqm for a stand up to 15 sqm – 2 sqm for a larger stand

spotlights LED 30W > 1 spotlight / 3 sqm

+ A floor marker with your stand number

If your company ordered a BASIC STAND (raw space), upgrade for **500 euros / sq.m.**

If your company ordered a FORMULE + Shell stand, upgrade for **300 euros / sq.m.**

To upgrade, [\*\*CLICK HERE\*\*](#)

+ send a mail to [info@pro4events.com](mailto:info@pro4events.com)

(deadline 30 June, 2024)

Paris  
Session 2024



## Requirements to apply as a start-up :

- > Have an independant legal body
- > Be up to 5 years old
- > Size of 50 people maximum
- > Be aimed at creating, improving and expanding a scalable, innovative, technology-enabled product in the field of CIGRE activities
- > A start-up who would already have reserved a booth for CIGRE 2024 exhibition can take part, but cannot cancel its booth
- > Comply with the exhibitor's rules & accept the general conditions
- > Only small devices & products for display are accepted

## Limited space



Non contractual picture

H 2,50 x L 1 m

Shelf = 100 cm long / 30 cm wide

Send your LOGO to  
[info@pro4events.com](mailto:info@pro4events.com)  
JPEG HD definition

### Package :

- 1 desktop with LOGO of the company
- 1 high chair
- Power & electrical outlet
- Exhibition badges (limited number)
- Company name & contact printed in the Guide book and displayed on the mobile App
- Access to the Opening ceremony, Press center & Job Center
- Possibility to give a pitch at lunch time hours "Start-up" Forum : first come, first served
- > send a request to [info@pro4events.com](mailto:info@pro4events.com)

Registration on <https://www.cigre-exhibition.com/form/>  
contact : [info@pro4events.com](mailto:info@pro4events.com)



Picture CIGRE 2022

Updated on 23 January, 2024

CIGRE 2024 Sunday 25 August > Friday 30 August, 2024  
VENUE : Palais des Congrès, Porte Maillot, Paris (VIPARIS)

## Please, transfer the following technical regulations to your stand contractor

### GENERAL INFORMATION

Safety rules regarding risks of fire and panic in establishments open to the public have been established by the Order dated June 25<sup>th</sup>, 1980 (general provisions). The Order dated November 18<sup>th</sup>, 1987, sets forth the specific provisions applicable to exhibition halls. The text below is excerpted from said regulations in order to facilitate understanding.

The Safety board is quite severe regarding stand construction (stability, construction and decoration materials, electrical installations, etc...). The decisions made during safety board inspections, the day before of the morning the event opens must be immediately implemented. Stand installation must be completed for Safety board inspections.

The Exhibitor (or his representative) must be present at the stand and be prepared to provide flammability reports for all materials used. Non-compliance with this rule may lead to the removal of such materials or a prohibition on opening the stand to the public. All large projects (Basic stands = construction on raw space) must be submitted to the trade show's safety Supervision for approval.

### A. STAND CONSTRUCTION RULES

**Stand drawings :** After registration, each Exhibition Manager will receive a private mail from the organiser Pro4events with the space and dimensions of the location booked > for any question, contact : [info@pro4events.com](mailto:info@pro4events.com)

Please, note :

> the size of a few locations (not all locations are concerned) may change slightly after a last SECURITY CHECK of the floor plan (with a difference of + or – 20% as compared to the surface initially booked)

> the position of the pillars is not accurate (+/- 30 cm)

You can take advantage of the pillars on the stand to increase visibility > see our post cladding offer *coming soon* > contact : [info@pro4events.com](mailto:info@pro4events.com)

#### ALL STAND PROJECT

or additional decoration to the shell-stand (formule plus or premium)

**are to be sent to the organiser Pro4events for approval BEFORE May 30, 2024**

Send a mail to : [stand-approval@pro4events.com](mailto:stand-approval@pro4events.com) / copy to [info@pro4events.com](mailto:info@pro4events.com)

Stand builders must ask the Exhibition Manager  
to validate the drawings before any submission to Pro4events

### Height of booth construction & signs :

The maximum height authorised for any construction in alignment with the gangways and next stands is fixed at **2.50 m** (platform included).

The maximum height for signs and construction is **3.00 m** with a distance of 1.00 m back from the next stands and from the gangways. Exemptions for signs may be granted on request.

There are different heights in the hall > please check on the floor plan and contact the organiser Pro4events for a **FINAL CHECK** > [info@pro4events.com](mailto:info@pro4events.com) & [stand-approval@pro4events.com](mailto:stand-approval@pro4events.com)

**Suspension from the framework** : The Palais des Congrès (VIPARIS) is the ONLY company allowed to install slings > [CLICK HERE for more information](#)

**Partition walls** : no more than 50 % of the total length along the gangways.

**Platform or raised floor** : in case exhibitors want to raise the floor, an access ramp is required.

**Signs** : illuminated signs are allowed. In no case, they may be intermittent or flashing. White letters on a green background are forbidden.

**Noise level** : the maximum allowed level of noise for advertising is 75 dB (at one meter from the ground).

**Maximum load** : Any exhibitor displaying elements or structures built with a total weight of more than 500 kg must send to the organizer ([info@pro4events.com](mailto:info@pro4events.com) & [stand-approval@pro4events.com](mailto:stand-approval@pro4events.com)), at the latest 3 months before the exhibition, a file of presentation with a certificate certifying that the distribution of the load on the ground of the together is less than 500 kg / square meter. During assembly and in case of doubt the intervention of an approved controller will be required and the following costs billed to the exhibitor.

**Overhead coverings** (ceiling, false ceiling, solid canopy) and awnings are allowed with restrictions & limitations and ONLY if authorised by the organiser and the venue  
> you have to submit your project to [info@pro4events.com](mailto:info@pro4events.com) & [stand-approval@pro4events.com](mailto:stand-approval@pro4events.com) for advise and final agreement.

### What is prohibited :

- Elevated floor stands (raised floor is allowed)
- Borings into the ground
- Curtains, drapes and net curtains in front of exits,
- Paint and varnish classified as inflammable (nitrocellulose or glycerophthalic for example),
- Use of sign or advertisement panels in white letters on a green background,
- stands with more than 1 level
- Closed stands or rooms (in case, you have an exceptional authorization from the organiser, you have to submit your project to [info@pro4events.com](mailto:info@pro4events.com) & [stand-approval@pro4events.com](mailto:stand-approval@pro4events.com) for final agreement).

### Number and width of exits :

If S is < 19 sq.m: 1 of 0.90m

20 sq.m ≤ S < 50 sq.m: 1 x 0,90m and 1 x 0,60m

50 sq.m ≤ S < 100 sq.m: 2 x 0,90m or 1 de 1,40m and 1 x 0,60m

100 sq.m ≤ S < 200 sq.m: 1 x 1,40m and 1 x 0,90m or 3 x 0,90m

200 sq.m ≤ S < 300 sq.m: 2 x 1,40m

S > 300 sq.m, please contact HERVE PIERRE SAS / Mr. Charles JARDINIER / 2 rue Maurice UTRILLO / 95110 SANNOIS / > [charles.jardinier@orange.fr](mailto:charles.jardinier@orange.fr)

Exits should be carefully positioned and marked (S = surface)

### Accessibility for persons of reduced mobility (PRM)

The Exhibitor must comply with French regulations and with the accessibility order. These regulations specify that all premises and facilities open to the public must allow access to the disabled and to people with reduced mobility. This means that one or several ramps, of a minimum width of 90 cm, will facilitate access. Slopes will respect the following percentages:

- 4 % slope without limit to the length of the passageway
- 5 % slope on a length of less than 10m
- 8 % slope on a length of less than 2m
- 10 % slope on a length of less than 0.5m
- 33% slope for a threshold of 4 cm (ie a depth of 12 cm for a floor height 4 cm)

Clearance of a radius of 1.5 m will be left free for manoeuvring at each end of the ramp.

Welcome and information desks must be accessible to people using a wheelchair: height 80 cm, a gap of 30 cm depth on a height of 70 cm, enabling space for knees.

Width of 1.4 m minimum for pathways.

Ramps with minimum width of 90 cm are requested.

**PRO4EVENTS reserves the right to have any stand, not respecting the General Regulations, modified by a company of his choice, and at the Exhibitor's own expense.**

## B. FIRE SAFETY RULES

Fire and panic risk prevention regulations establishments frequented by the public are specified in the Ministerial Order dated 25 June 1980 (general provision). The ministerial Order dated 18 November 1987 stipulates the special measures applicable to exhibition halls. The text below is composed of extracts from these regulations in order to facilitate comprehension.

Any information concerning fire safety can be obtained before the Event from: **HERVE PIERRE SAS / Mr. Charles JARDINIER / 2 rue Maurice UTRILLO / 95110 SANNOIS / e-mail : [charles.jardinier@orange.fr](mailto:charles.jardinier@orange.fr)**

During the setting-up period, Mr Charles Jardinier will ensure that all security measures indicated here are applied.

### Materials :

The materials used must comply with fire reaction characteristics. They are classified into 5 categories M0, M1, M2, M3, and M4 (M0 corresponds to an incombustible material).

### Requirements :

- Stand framework and partitions classified **M3** as a minimum,
- Large pieces of furniture (boxes, counters, presentation cases, screening, etc.) classified **M3** as a minimum,
- Wall coverings (natural or plastic fabrics) classified **M2** as a minimum (they may be stretched or fixed with staples; Sundry finishes (fabrics, paper, plastic film) which are very thin (1 mm maximum) may be used when fixed in a full bed of adhesive to backgrounds of M0, M1 M2 or M3 materials. Embossed or textured paper, however, must be fixed in a full bed of adhesive onto M0 materials only),
- Materials on display : Materials on display may be shown on the stands without any requirements for fire resistance. However, if those materials are used for decorating the partitions of false ceilings, and if they represent more than 20 % of the total area of these elements, the requirements in the above paragraphs shall be applicable to them,
- Floral decoration : Limited use should be made of floral decorations in synthetic materials. If this is not the case, these decorations must be made from **M2** materials,
- Curtains, drapes and loose net curtains classified **M2** as a minimum (They are forbidden on entrances and exits to the stands, but permitted on doors to internal rooms),
- Paints & varnishes : strictly forbidden if they are deemed to be inflammable (based on nitro-cellulose or alkyds for example),
- Floor covering must be firmly fixed, classified **M4** as a minimum,
- Covering for podium, platforms or tiered seating (if > 0,30 m and if S> 20 sq.m.) classified **M3** as a minimum (h = height, S = surface),
- Floating decorative elements or trims (advertisement panel if S > 0,50 sq.m., garlands, light decorative objects, etc.), classified **M1** as a minimum (the use of signs or advertising panels using white letters on a green background is strictly forbidden, as the colours are reserved exclusively for indicating exits and emergency exits),
- Canopies, if building fitted with sprinklers, classified **M2** as a minimum, otherwise **M1**, CNPP-approved mesh canopies. (CNPP – French Test Laboratory).

### Equivalences for wood :

- Non-resinous solid wood : if thickness  $\geq 14$  mm, classified **M3**,
- Resinous solid wood : if thickness  $\geq 18$  mm, classified **M3**,
- Panels made from wood derivatives (plywood, boards, wood fibres, chipboard) : if thickness  $\geq 18$  mm, must be classified **M3**.

### Fire classification

Classes selon NF EN 13501-1 (hors sol)			classes selon NF EN 13501-1 (hors sol)				
A1	-	-	Incombustible	C	s1		M2
A2	s1	d0	M0		s2	d0	
A2	s1	d1	M1		s3	d1	
A2	s2	d0	M1	D	s1		M3
	s3	d1			s2	d0	M4
B	s1			E-d2 à F	s3	d1	non goutant
	s2	d0					M4
	s3	d1		SOL			
C	s1		Bfl				M4
	s2	d0		s1			
	s3	d1		s2			



### Fire certificates

At any time, the Security Manager may request exhibitors the official report giving the fire classification of materials used in stand construction or failing this, the equivalent fireproofing certificates. All coatings, coverings and material meeting the requirements of security are sold in specialized shops, where the quality certificates as regards the classification of fire resistance may be obtained from the :  
Groupement NON FEU / 37-39, rue de Neuilly BP 121 / 92113 Clichy Cedex / Tel. 01 47 56 30 80

### Fireproofing certificates

By means of different procedures or applications, any material which normally would be of medium or high flammability, may obtain the flame resisting qualification of M2. These procedures would be: inflammable liquid spraying, brush application of a paint or special varnish or immersion in a special bath solution. These operations of fireproofing may be performed by an officially qualified person or contracting company who may issue a homologated certificate giving the following specifications. The exact names, addresses and telephones may be obtained from the :

Groupement Technique Français de l'ignifugation / 10, rue du Débarcadère / 75852 Paris cedex 17 / Tel. 01 40 55 13 13  
Reports of foreign origin cannot be taken into consideration. Only reports issued by approved French laboratories can be accepted.

### Exhibitors obligations

Exhibitors must keep on their stands the official report giving the fire classification of materials used in stand construction, (failing this, the equivalent fireproofing certificates).

It shall be strictly forbidden to set any type of fitting out whatsoever over the aisles (structure of signboards, walkway, etc).

## C. POWER SUPPLY & ELECTRICAL INSTALLATION

Exhibitors need to order power supply for the stand > choose to order the "Ready to Exhibit package" (Electricity + Furniture + (or) TV Led screens) = 1 supplier / 1 invoice, all in one & customized service managed by Pro4events (order form at the end of this document > contact [info@pro4events.com](mailto:info@pro4events.com)), or order on VIPARIS Store.

### Electrical installation (by VIPARIS) :

- Electrical connections must be made inside connecting boxes,
- The electrical cut-off devices must be permanently accessible to the staff on the stand,
- The installations must only have fixed wiring systems,
- Cables and conductors must be category C2,
- Ducts and rails used to route cable, and cable covers must be flame-resistant, in compliance with the current standards,
- All wiring systems must have a protection conductor connected to the earth terminal on the electricity supply panel,
- If class 0 materials exhibited are powered up, they must be protected by residual current mechanisms set a maximum of 30 mA,
- Class 1 appliances must be connected to the protective conductor of the wiring system supplying the power,
- the use of individual protected earth sockets is prohibited.

Electricity junction boxes and supply panel cupboards: These must be in a metal casing, inaccessible to the public, easily by staff and fires services, sited away from all flammable and combustible materials and products.

### IMPORTANT : if the power supply is more than 100 kVA

- The supply panel must be in a cupboard dedicated solely to this use,
  - The location must be signed,
  - A CO2 or powder extinguisher must be adjacent,
  - Partitions must be classified M3,
  - The supply panel must not be located under a mezzanine floor accessible to the public,
- A declaration is required if the power supply exceeds 100 kVA.

### Halogen lamps (EN 60598 standard) Halogen stand lighting must :

- be fixed at a minimum height of 2,25 m,
- be kept away from any flammable materials (at least in 0,50 metres from wood and other decorative materials),
- be firmly fixed,
- be fitted with a safety screen (glass or fine mesh grill) to provide protection from a possible explosion of the lamp.

### High-voltage illuminated signs These must :

- be protected by a screen made of a material in class M3 at least. The switch to turn them off shall be indicated and the transformers shall be placed in a position that cannot cause any danger,
- have a clearly-labelled "off" switch,
- have transformers out of people's reach,
- have "danger, high voltage" notices as required.

### **PROHIBITED EQUIPMENT, PRODUCT, GASES :**

- Multiple sockets and adaptors are prohibited. Only connecting boxes shall be permitted,
- The distribution of samples or products containing an inflammable gas,
- Balloons inflated with a flammable or toxic gas,
- Articles made of celluloid,
- The presence of pyrotechnic or explosives devices,
- The presence of ethyl oxide, carbon sulphide, sulphuric ether and acetone,
- The use of acetylene, oxygen, hydrogen or equivalent high-risk gases. Note: a request for dispensation can be submitted to the French administration,
- Pyrotechnic effects, devices producing detonations, sparks or flames,
- Use of flammable liquids is prohibited inside the Venue VIPARIS but for exceptional use, ONLY after authorisation, it must be limited to the following quantities per stand : 10 litres of flammable liquids of 2nd category for 10 m<sup>2</sup> of stand, with a maximum of 80 litres, 5 litres of flammable liquids of 1st category.

### **EMERGENCY RESSOURCES**

- These must remain permanently visible and reachable
- If there is a fire hose point (RIA) on the stand, a one-meter wide passage from the aisle must be provided to give permanent access. Signs must be visible.

### **OPERATING INSTRUCTIONS**

- It is prohibited to deposit boxes or stock cases, wood, straw, cardboard, etc... in the Exhibition halls, on the stands or in the aisles. Emergency equipment must remain visible at all times. Daily cleaning is necessary to clear the premises of rubbish of all kinds.

### **D. SANITARY MEASURES**

The venue, VIPARIS, has been accredited with the label « **Safe V Events** » from an independent authority.

All the necessary health measures are taken to ensure the highest standards during the Session :

- > **Disinfection** of rooms, common areas, surfaces, equipment, lifts at all times, hand sanitiser available, air recycling,
- > **Medical Center** with dedicated medical staff on level 3 (room 335).

### **E. SECURITY**

To ensure your safety during your stay at the venue VIPARIS, we have increased the number of agents during the Session, in addition to webcams. **BE AWARE that it will take longer to access the Session. Security check is required before entering the Congress Center.**

Please be reminded that the venue is a NON-SMOKING building. The consumption of alcohol is strictly forbidden and during the set up and dismantling of events.

### **F. DELIVERY OF GOODS**

Please contact **ESI** for all your deliveries > [florentin.fasoli@group-esi.com](mailto:florentin.fasoli@group-esi.com) [Emmanuel.pitchelu@group-esi.com](mailto:Emmanuel.pitchelu@group-esi.com)

The venue, VIPARIS, is requesting registration of vehicles prior to the delivery > on <http://logipass.viparis.com>

It is prohibited to deposit boxes or stock cases, wood, straw, cardboard, etc... in the Exhibition halls, on the stands or in the aisles.

Emergency equipment must remain visible at all times.

Exhibitors can be invoiced by VIPARIS for waste removal > <https://www.viparisstore.com/en/#>

More information in the Exhibitors' guide on line > [www.cigre-exhibition.com/exhibitors/exhibitors-guide/](http://www.cigre-exhibition.com/exhibitors/exhibitors-guide/)

Contact : [info@pro4events.com](mailto:info@pro4events.com)

Pro4events hereby reserves the right to modify any stand that fails to comply with the present rules and general conditions by any company of its choice and at the sole expense of the exhibitor.

> see the General Conditions on : [CIGRE 2024 GENERAL RULES \(www.cigre-exhibition.com/form/cgv/\)](http://www.cigre-exhibition.com/form/cgv/)

This document has been updated on 31 January, 2024 and is subject to changes at any time



# BUILDING & DISMANTLING TIMES

Paris  
Session 2024



## BUILDING TIMES FOR BASIC (= raw space) :

Friday 23 August : from 8 am to 8 pm  
Saturday 24 August : from 8 am to 8 pm  
Sunday 25 August : from 8 am to 1:30 pm

## BUILDING TIMES FOR SHELL (= Formule plus) and PREMIUM stands :

Saturday 24 August : from 2 pm to 8 pm  
Sunday 25 August : from 8 am to 1:30 pm

**Stands must be ready on Sunday 25 August at 1.30 pm**

**The exhibition opens at 2 pm**

## DISMANTLING TIMES

Friday 30 August : from 4:30 pm to midnight  
Saturday 31 August : from 8 am to 12 pm (noon)

No badge is required during the building and dismantling times  
(when the exhibition is closed)

# TRANSPORT – CUSTOMS – LOADING & UNLOADING

**FOR ALL YOUR DELIVERIES > please, contact ESI**  
[florentin.fasoli@group-esi.com](mailto:florentin.fasoli@group-esi.com)    [Emmanuel.pitchelu@group-esi.com](mailto:Emmanuel.pitchelu@group-esi.com)



## ESI is the official freight forwarder and exclusive lifting contractor CIGRE 2024 :

Transport from any country of origin (air, sea, road), Customs formalities, Warehousing (before & after event), Transfer to show site & delivery on stand, On-site handlings & assistance, Heavy lifting, Storage of empty packages, Return shipment to any destination (air, sea, road)

QUOTATION REQUEST to be sent to [florentin.fasoli@group-esi.com](mailto:florentin.fasoli@group-esi.com) / [Emmanuel.pitchelu@group-esi.com](mailto:Emmanuel.pitchelu@group-esi.com)

Your Company /  
 Société : \_\_\_\_\_  
 Country / Pays : \_\_\_\_\_  
 Tel : \_\_\_\_\_

Name / Nom : \_\_\_\_\_  
 E-mail : \_\_\_\_\_  
 VAT / TVA : \_\_\_\_\_

Level and stand number at CIGRE 2024 : .....

- Preliminary transport from your address to ESI warehouse :
  - arranged by yourselves
  - arranged by ESI (please advise country, city, zipcode): \_\_\_\_\_
- Place of reception of parcels by ESI :
  - ESI warehouse (CDG airport area)
  - show site directly (full trucks only)
- Inbound on-site handling :
  - unloading only
  - unloading & delivery on stand
- Collection, storage, redelivery of empty packages
- Outbound on-site handling :
  - collection on stand & reloading
  - reloading only
- Return transport :
  - transfer to ESI warehouse for collection by yourself
  - delivery to your address
- Other services requested : \_\_\_\_\_

Paris  
Session 2024



CARGO DETAILS COLISAGE	Nber parcels Nbre colis	Dimensions	Total weight Poids total	KG	Total volume Volume total	M3

**SPECIFICATIONS** (crates / pallets / loose cargo / perishable / non-stackable, etc...) - **PARTICULARITES** (caisses / palettes / vrac / périssable / non gerbable, etc...) \_\_\_\_\_

>> [DOWNLOAD the FORM HERE](#)

Document updated on March 30, 2024 - Informations are subject to change at any time  
 Pro4events, 3-17 chemin du Lanfonnet – 74320 Sevrier – France  
 e-mail [info@pro4events.com](mailto:info@pro4events.com) / [www.cigre-exhibition.com](http://www.cigre-exhibition.com)

# DELIVERY OF GOODS

## LOGIPASS platform BY VIPARIS

It is mandatory to register ALL vehicles on line



Paris  
Session 2024



We remind you that registration of vehicles online is MANDATORY prior to the delivery OR to pick up your goods after dismantling via the LOGIPASS platform of the venue : <https://logipass.viparis.com/en/>  
Hotline +33 (0)1 40 68 11 30 / infos-exposants@viparis.com



Access to the delivery area  
54 boulevard Gouvion-Saint-Cyr  
75017 Paris  
LEVEL -2

Maximum height : 4,20 m  
Width of access ramps : 3,50 m  
Gradient : 15%  
No parking is allowed in the delivery area

Non contractual document  
subject to changes at any time

**SMALL PARCELS**  
we advise you to send small parcels to your hotel to make sure to get them on time



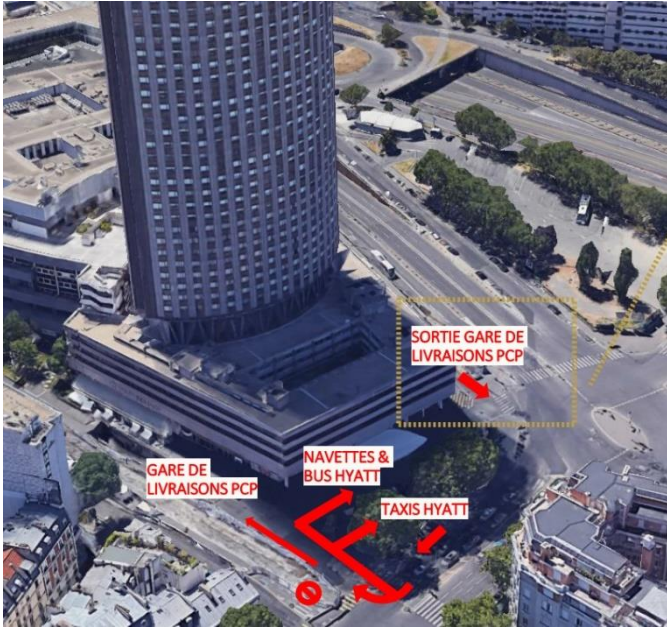

Parking time for heavy trucks limited to 4 hours maximum

For utilities, limited to 2 hours maximum

**ACCESS FOR DELIVERY ONLY**

**NO OVERNIGHT PARKING**

**FOR ALL YOUR DELIVERIES > please, contact ESI**  
[florentin.fasoli@group-esi.com](mailto:florentin.fasoli@group-esi.com)    [Emmanuel.pitchelu@group-esi.com](mailto:Emmanuel.pitchelu@group-esi.com)

The goods lifts operate ONLY during building-up and dismantling times

**Access to Level 1 with lifts 6 & 8 (CLOSED on SUNDAY 25 August)**

**BUILDING TIMES FOR BASIC (= raw space) :**

Friday 23 August : from 8 pm to 8 pm  
 Saturday 24 August : from 8 am to 8 pm  
 Sunday 25 August : from 8 am to 1:30 pm

**BUILDING TIMES FOR SHELL (= Formule plus) and PREMIUM stands :**

Saturday 24 August : from 2 pm to 8 pm  
 Sunday 25 August : from 8 am to 1:30 pm

**DISMANTLING TIMES**

Friday 30 August : from 4:30 pm to midnight  
 Saturday 31 August : from 8 am to 12 pm (noon)

**USE ONLY LIFTS MC6 & MC7 and MC8 & MC9**

**MC6 & MC7**

Load : 4 tons  
 Height : 2,08 m  
 Depth : 2,90 m  
 Width : 2,15 m

**MC8 & MC9**

Load : 11 tons  
 Height : 2,20 m  
 Depth : 6,80 m  
 Width : 2,60 m

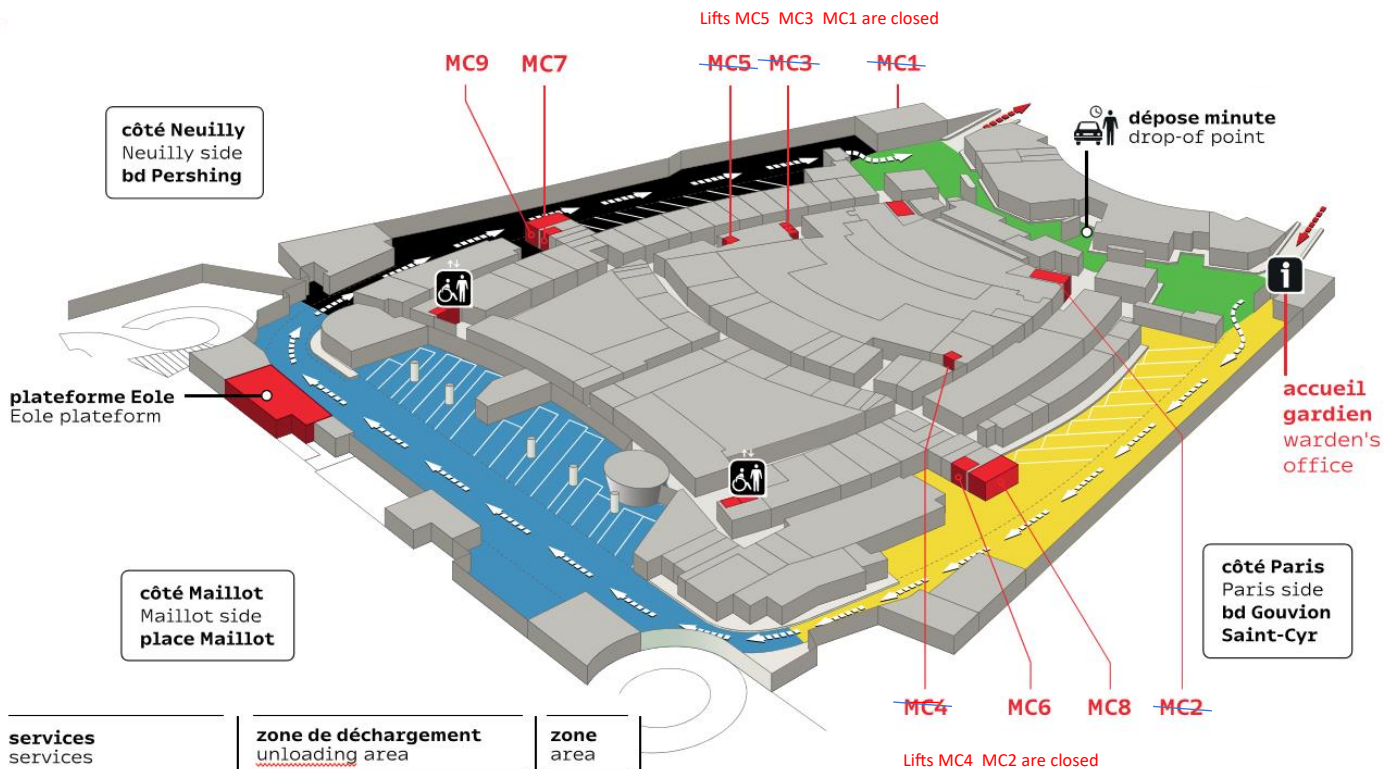

MORE INFORMATION COMING SOON Non contractual document - subject to changes at any time

Document updated on March 30, 2024 - Informations are subject to change at any time

Pro4events, 3-17 chemin du Lanfonnet – 74320 Sevrier – France  
 e-mail [info@pro4events.com](mailto:info@pro4events.com) / [www.cigre-exhibition.com](http://www.cigre-exhibition.com)

## FOR YOUR COMMUNICATION

included in your package

Paris  
Session 2024



### EXHIBITORS' PROFILE to register on line

As soon as possible

#### Publish information on your company

Name of company, Address, General mail address, Fields of activity, General activity & products of your company

in the **GUIDE BOOK** (= 8500 catalogues distributed during the event)  
+ on the **MOBILE APP** (+11000 app downloads last Session)  
no extra cost

> **Complete the form on line**

[www.cigre-exhibition.com/exhibitors/exhibitors-guide/guidebook-registration/](http://www.cigre-exhibition.com/exhibitors/exhibitors-guide/guidebook-registration/)

**OPEN TO EXHIBITORS & CO-EXHIBITORS** > Please, inform your co-exhibitor & copy to [info@pro4events.com](mailto:info@pro4events.com)

**NEW DEADLINE : 04 April 2024**

## Advertising banner for prospects

included in your package

**Download the CIGRE ADVERTISING BANNER for your clients, visitors > [CLICK HERE](#)**

You are invited to insert the banner in your mails or website...

We remind you that visitors need to register online to access the Technical Exhibition (opening from 2 pm on Sunday 25 August). Visitors are also invited to attend the Opening Ceremony on Sunday at 3:30 pm & the welcome cocktail afterwards, until 7:30 pm.

The cost for each visitor's badge is 150 euros if the order is placed before July 20, 2024 (or 300 euros per badge after this date).

**VISIT US at CIGRE Technical Exhibition**  
300 exhibitors • 8600 attendees • 95<sup>th</sup> international audience

**REGISTRATION ON**  
[www.cigre-exhibition.com/visitors/](http://www.cigre-exhibition.com/visitors/)  
EARLY BIRD price: 150 € (before 20 July)  
REGULAR price: 300 €

25 > 30 August, 2024  
PALAIS DES CONGRES - Paris  
[session.cigre.org](http://session.cigre.org)

The world's leading global event  
for sharing power system expertise

PARIS  
SESSION 2024 CIGRE

Document updated on 31 January, 2024 - Informations are subject to change at any time

Pro4events, 3-17 chemin du Lanfonnet – 74320 Sevrier – France  
e-mail [info@pro4events.com](mailto:info@pro4events.com) / [www.cigre-exhibition.com](http://www.cigre-exhibition.com)



## FOR YOUR COMMUNICATION

PACK SERVICES included in your package

Paris  
Session 2024



### PACK SERVICES included in your package

#### Press releases for journalists

A press room is organized for the journalists attending the Session, open to exhibitors wishing to leave Press kits, Press releases or any Press materials (usb keys,..) dedicated to journalists. If you know a journalist interested in participating at CIGRE 2024, a press accreditation is required.

**Sales presentations, Business meetings** > Book a Working (limited to 1 hour) +/- or a Meeting room (limited to 1 hour) during the event – for up to 20 people – equipped with a monitor 46" and HDMI connection > Register a slot before the event (first come, first served) > [CLICK HERE](#)

#### Job offers

A Job Center is organized for all the attendees during the Session. Exhibitors are invited to post their job offers and look at résumés.

CONTACT : [sandrine.huchez@pro4events.com](mailto:sandrine.huchez@pro4events.com) FORMS to be completed > [CLICK HERE](#)

#### Networking :

##### Access to the Opening Ceremony

The Opening Ceremony is on Sunday 25 August, 2024, starting at 3:30

Location : Grand Amphi – Access LEVEL 2

Exhibitors are invited to attend the conference

**WELCOME DRINKS** : Just after the Opening Ceremony, Welcome drinks will be held on the 3 levels

### ON SITE > GO TO THE EXHIBITORS' OFFICE (open from Sunday 25 August, 9 am)

on LEVEL 3 – ROOMS 304 + 305 – Paris side

with the Press center, keys for the allocated meeting rooms, Information & Registration for the next Sessions: CIGRE CANADA 2024, CIGRE SYMPOSIUM CANADA 2025, CIGRE PARIS 2026

contact > [sandrine.huchez@pro4events.com](mailto:sandrine.huchez@pro4events.com)



JOB CENTER on Level 3, Paris side

CIGRE 2022 - Non contractual pictures

> [CLICK HERE to register](#)

First come, First served

# SERVICES TO ORDER for the stand

Deadline 15 April, 2024

Paris  
Session 2024



Choose the “Ready to Exhibit” Package  
managed by Pro4events

**ELECTRICITY (mandatory) + FURNITURE + TV LED SCREEN (if needed)**

**> CHOOSE TO HAVE ONLY 1 SUPPLIER = 1 INVOICE, ALL IN ONE !**

**> CUSTOMISED SERVICE**

Pro4events team takes care of your orders, replies to your technical questions,  
and gives you feedback

List of prices next pages – **ORDER FORM at the end of this document**  
contact > [info@pro4events.com](mailto:info@pro4events.com) / [marion.caumont@pro4events.com](mailto:marion.caumont@pro4events.com)

**Example of a “Ready to Exhibit” Package for a 9 sqm SHELL (formule +)  
or PREMIUM stand :**

**ELECTRICITY** (mandatory to order)

> Example : 3KW = 415 euros (limited period power supply)

+

IN OPTION :

**FURNITURE** > choose from the [CATALOGUE ON LINE HERE](#)

> Example : 1 table (price from 80 euros) + 2 chairs (price from 20 x2 euros) + 1 corbeille (bin) for 8 euros + 1 display unit for brochures (price from 100 euros)...

IN OPTION :

**TV LED SCREEN** (price from 300 euros...)

> With the “Ready to Exhibit” package, Pro4events is taking care of your orders & sends you only 1 invoice for ALL the services.

List of prices next pages – **ORDER FORM at the end of this document**

Paris  
Session 2024



Document updated on March 30, 2024 - Informations are subject to change at any time  
Pro4events, 3-17 chemin du Lanfonnet – 74320 Sevrier – France  
e-mail [info@pro4events.com](mailto:info@pro4events.com) / [www.cigre-exhibition.com](http://www.cigre-exhibition.com)



# ELECTRICITY (power supply)

(it is mandatory to order power supply for the stand)

1/ Evaluate the power needed for the stand >>

Average power, subject to changes	
➤	Coffee machine : 1,3 kw – 2 kw
➤	Fridge : 0,2 kw
➤	Kettle = 1kw
➤	Microwaves = 1kw
➤	Laptop = 0,1kw
➤	Screen : 0,2 kw
➤	Computer = 0,5kw
➤	Printer/copy machine = 2,5kw
➤	3 led spots = 1kw

2/ Choose to ORDER Power supply with the “READY TO EXHIBIT” Package  
 = customized service managed by Pro4events (order form > [CLICK HERE](#))  
 or with the venue on Viparis store > <https://www.viparisstore.com/en/#>

3/ Note the reference & description to complete the ORDER FORM at the end of this document > send it to [info@pro4events.com](mailto:info@pro4events.com) / [marion.caumont@pro4events.com](mailto:marion.caumont@pro4events.com)

4/ Complete the STAND PLAN at the end of this document

## PRICES

### Limited period of power supply – No power during the night

Generated from renewable sources

Reference	Description	Price in € excl. VAT
09003	Limited Period Power Supply - 3kW/13A	415€
09004	Limited Period Power Supply - 4kW/16A	640€
09006	Limited Period Power Supply - 6kW/8A	800€
09008	Limited Period Power Supply - 8kW/20A	900€
10010	Intermittent electrical supply - 10kW/25A	1000€
10012	Limited Period Power Supply - 12kW/26A	1020€
10020	Limited Period Power Supply - 20kW/32A	1290€
10030	Limited Period Power Supply - 30kW/50A - 240/400V	1420€
10040	Limited Period Power Supply - 40kW/63A - 240/400V	1560€



Please note, orders placed from 08/20/2024 will be increased by 20%

Prices are in Euros and fixed for the duration of the event - VAT excluded (for French companies only)

Need of more power > contact : [info@pro4events.com](mailto:info@pro4events.com) / [marion.caumont@pro4events.com](mailto:marion.caumont@pro4events.com)

## 24h/24 POWER SUPPLY :

Reference	Description	Price in € excl. taxes
11003	24h/24 Period power supply - 3kW/13A	545€
11004	24h/24 Period power supply - 4kW/16A	840€
11006	24h/24 Period power supply - 6kW/8A	1030€
12008	24h/24 Period power supply - 8kW/12A	1175€
12010	24h/24 Period power supply - 10kW/16A	1290€
12012	24h/24 Period power supply - 12kW/20A	1330€
12020	24h/24 Period Power Supply - 20kW/32A	1675€
12030	24h/24 Period Power Supply - 30kW/50A - 240/400V	1840€
12040	24h/24 Period Power Supply - 40kW/63A - 240/400V	2025€

Paris  
Session 2024



Please note, orders placed from 08/20/2024 will be increased by 20%

Prices are in Euros and fixed for the duration of the event - VAT excluded (for French companies only)

Need of more power > contact : [info@pro4events.com](mailto:info@pro4events.com) / [marion.caumont@pro4events.com](mailto:marion.caumont@pro4events.com)

Orders cannot be changed after 30 June, 2024 - Any cancellation of the electrical boxes on site will be invoiced.

Do not forget to leave an access to the electrical panel during all the event



PICTURES ARE NON CONTRACTUAL

**VIPARIS will install the Electrical box on the stand**  
**Exhibitors cannot choose the type of electrical box**

Electrical box up to 8kw  
with 3 single phase sockets of 240V-16A  
44 x 25 x 21 cm



socket  
« WIELAND »

Electrical box KELIPSE up to 6kw  
with sockets  
91 x 29



Electrical box up to 20 kw  
44,5 x 25 x 21,5



BOX 30 kw (50A) 40 kw (63A)

Document updated on March 30, 2024 - Informations are subject to change at any time

Pro4events, 3-17 chemin du Lanfonnet – 74320 Sevrier – France  
e-mail [info@pro4events.com](mailto:info@pro4events.com) / [www.cigre-exhibition.com](http://www.cigre-exhibition.com)

1/ choose to order **FURNITURE (and / or) a TV LCD SCREEN** with the **“READY TO EXHIBIT” Package**  
= customized service managed by Pro4events > Electricity + Furniture + TV LCD screen, All in one.  
or order Furniture with Camerus (excluded screens) > <https://camerus.com/en/salon/cigre-2024/>

2/ Note the reference & description to complete the ORDER FORM at the end of this document > send it to  
[info@pro4events.com](mailto:info@pro4events.com) / [marion.caumont@pro4events.com](mailto:marion.caumont@pro4events.com)

## TABLES, CHAIRS, STORAGE, DISPLAY UNITS, COFFEE MACHINES.....

> CLICK on the links below

[Chairs](#), [Armchairs](#), [Stools](#), [Lounge seating](#), [Ottomans & Benchs](#)

[Standard tables](#), [Tall Tables](#), [Coffee tables](#), [Desks](#)

[Counters & Storage](#), [Display units & Shelves](#), [Showcases](#)

[Fridges / Water fountains](#) [Coffee machines](#) [Lighting](#)

+ / or

## TV LCD SCREEN

Description	Price in € excl VAT
LCD 32'	300 €
LCD 43'	410 €
LCD 50'	500 €
LCD 55'	570 €
LCD 75'	950 €



Non contractual pictures

ALL TV's are supported by a foot (there is no offer for TV's mounted on a wall)

Prices are in Euros and fixed for the duration of the event - VAT excluded - Orders placed from 08/20/2024 will be increased by 20%

Delivery of furniture & installation of the TV on the stand is included

# STORAGE ROOM

## For Formule + stands ONLY in OPTION

Premium stands have already a storage room, included in the package

- 1/ Complete the ORDER FORM at the end of this document if you need a storage room for your Formule + (shell) stand
- 2/ Indicate the location of the storage room on the floor plan at the end of this document  
Do not forget to position your stand (aisle, nearby stand...)

Architecture (1) (2)	Price VAT excluded
Storage room 1,00 m x 1,00 m	210 euros
Storage room 1,00 m x 2,00 m with a key to close the room	250 euros

(1) In addition to Formule Plus shell-stand partitions

(2) All prices are including delivery and manpower. All damaged items will be invoiced to the exhibitor.

Please note, orders placed from 08/20/2024 will be increased by 20%

Prices are in Euros and fixed for the duration of the event - VAT excluded

Paris  
Session 2024



Document updated on March 30, 2024 - Informations are subject to change at any time

Pro4events, 3-17 chemin du Lanfonnet – 74320 Sevrier – France

e-mail [info@pro4events.com](mailto:info@pro4events.com) / [www.cigre-exhibition.com](http://www.cigre-exhibition.com)

# RIGGING STRUCTURES

suspension (hanging) points

ORDER FROM VIPARIS



The Palais des Congrès (VIPARIS) is the **ONLY** company allowed to install slings.

**Maximum weight by hanging point : 5 kg**

Obligation of a point all the 1m – 1m50 according on the signage to hang

**Maximal size for suspended signage : 5 m**

If your signage is longer than 5 m, it necessarily has to have a grip on the ground.

Materials authorized for your structure: Drop, cover, fine PVC (above 4 mm) or wood against plated.

To be validated your request must be necessarily accompanied by a plan with its orientation in the hall or the space + a rise and/or seen in prospect (perspective).

The delivered service includes exclusively the hanging point. The catcher of the structure must be made by the exhibitor or the decorator of the pit.

Any hanging point in the ceilings of the Palais des Congrès de Paris has to be the object of an estimate.

Price for each hanging point should be **123,40 euros** (Excl. VAT) – this price includes only the installation of the hanging point > For more information and quotation, please, contact VIPARIS.

[CLICK HERE TO SEE THE VIPARIS FORM & PRICE](#)

> CONTACT VIPARIS [mounia.bennekrouf@viparis.com](mailto:mounia.bennekrouf@viparis.com)

[rabah.aouadi@viparis.com](mailto:rabah.aouadi@viparis.com)

and on VIPARIS STORE <https://www.viparisstore.com/en/#>

Paris  
Session 2024







## WIFI

Included in the Exhibitors' package

Paris  
Session 2024



### WIFI 2.4 Ghz is included in your package

#### WIRED INTERNET ORDER on VIPARIS store > <https://www.viparisstore.com/en/#>

VIPARIS's plug-and-play options provide Internet connections that are automatically configured in DHCP. You can enjoy immediate access to a private IP address, at rates which vary depending on bandwidth.

Reference	Description	Price in € excl. taxes
51455_PCP	6 Mbps symmetric Internet connection	762.17
51413_PCP	10 Mbps symmetric Internet connection	1460.66
51321_PCP	Public IP address	37.65
51383_PCP	8 ports switch rental	76.16
51367_PCP	Wi-Fi hotspot activation	83.47



#### CUSTOMIZED WIFI ORDER on VIPARIS store > <https://www.viparisstore.com/en/#>

Bandwidth, a unique login and a customised password - our dedicated Expert Wi-Fi package offers various options designed to meet your needs. To keep things simple, you can benefit from between 4 and 20 Wi-Fi accounts, accessible via a single login and password. If our range of current options don't match your requirements, please contact Exhibitor Services (contact@e-viparisstore.com) for a quote for customized Wi-Fi services.

Reference	Description	Price in € excl. taxes
92400_PCP	Wi-Fi Expert 5GHz account (802.11 a/n standard)	103.48
51452_PCP	Wifi Expert 4 accounts 5Ghz (802.11 a/n) + 8Mbps symmetric Secure Internet speed	669.22
51459_PCP	Wifi Expert 8 accounts 5Ghz (802.11 a/n standard) + 12Mbps symmetric Secure Internet speed	1046.37
51454_PCP	Wifi Expert 20 accounts 5Ghz (802.11 a/n standard) + 20Mbps symmetric Secure Internet speed	2061.99

Please note, orders placed from 08/20/2024 will be increased by 20%

Prices are in Euros and fixed for the duration of the event - VAT excluded

Indicate the location of the cables & connections, on the **FLOOR PLAN** at the end of this document

Document updated on January 20, 2024 - Informations are subject to change at any time

Pro4events, 3-17 chemin du Lanfonnet – 74320 Sevrier – France

e-mail [info@pro4events.com](mailto:info@pro4events.com) / [www.cigre-exhibition.com](http://www.cigre-exhibition.com)

## LASER PRINTERS [ORDER on VIPARIS store > https://www.viparisstore.com/en/#](https://www.viparisstore.com/en/#)

Reference	Description	Price in € excl. taxes
LNIMP11_VIP	Laser Printer A4 - Black & White	165.00
LNIMP12_VIP	Laser Printer A4 - Color	225.00
LNIMP13_VIP	Laser printer A4/A3 - Color	757.00
LNMLT11_VIP	Small laser Multifunction A4 - Black & White	219.00
LNMLT12_VIP	Laser Multifunction Copier A4 - Color	263.00
LNMLT13_VIP	Laser Multifunction A4/A3 - Black and White	883.00
LNMLT14_VIP	Laser Multifunction A4/A3 - Color	1305.00



Exhibitors are responsible for the equipment. Do not leave it unattended. Exhibitors must be present when it is delivered.

## LAPTOPS & DESKTOPS

Reference	Description	Price in € excl. taxes
LNAIO23_VIP	All-in-one PC LED 23"	272.00
LNAIO23T_VIP	PC LED 23" TOUCHSCREEN pack / Wifi 5Ghz	291.00
LNPC218_VIP	Samsung Galaxy TAB 10,1"	88.00
LNPC217_VIP	PC Core i7 / Screen 15" Full HD laptop	435.00
LNPC213_VIP	PC Core i5 / Screen 17" laptop with Wifi key 5Ghz	305.00
LNLCD24S_VIP	24" LCD Screen (rented with desktop or laptop)	70.00
LNLCD28S_VIP	28" LCD Screen (rented with laptop)	130.00
LNLCDTO_VIP	Totem base for 24" to 28" LCD screens	73.00
LNLCDSEUL_VIP	Overcut for LCD screen rented without laptop	73.00

Please note, orders placed from 08/20/2024 will be increased by 20%  
Prices are in Euros and fixed for the duration of the event - VAT excluded

## APPLE PRODUCTS

Reference	Description	Price in € excl. taxes
LNIPAD4_VIP	IPAD Pro 12,9" ®	196.00
LNIPAD3_VIP	IPAD Air 2®	95.00
LNIPAD2_VIP	Floor display for iPad (cannot be rented alone)	73.00
LNMC312_VIP	MacBook TFT 15"	413.00
LNMC113_VIP	LED iMac 21,5" Retina	324.00
LNMC114_VIP	iMac LED 27" Core 2Duo	365.00

## TELEPHONE LINES

Reference	Description	Price in € excl. taxes
61235_PCP	IP phone line + IP device on rental + Communication Fee	379.31
51374_PCP	Ethernet over copper (EoC)	226.80

Prices are in Euros and fixed for the duration of the event - VAT excluded

## VIDEO PROJECTOR

Reference	Description	Price in € excl. taxes
NO87932_VIP	3600 lum Video projector + stand + Screen	520.00

Please note, orders placed from 08/20/2024 will be increased by 20%

Prices are in Euros and fixed for the duration of the event - VAT excluded

## ELECTRICAL EQUIPMENT

Reference	Description	Price in € excl. taxes
44113_PCP	Multi-socket power strip (3 sockets)	16.45
44121_PCP	Five-metre extension cable	16.45
52544_PCP	Power transformer	359.05
14130_PCP	Female P17 16A three-phase + N + E power socket + 0,50m of 6sq.mm cable	80.99
14179_PCP	Male P17 16A three-phase + N + E power socket + 0,50m of 6sq.mm cable	48.77
14131_PCP	Female P17 32A three-phase + N + E power socket + 0,50m of 6sq.mm cable	86.58
14174_PCP	Male P17 32A three-phase + N + E power socket - Includes 0,50metre cable (6mm2).	53.50
14132_PCP	Female P17 32A three-phase + N + E power socket + 0,50m of 6sq.mm cable	231.54
14175_PCP	Male P17 63A three-phase + N + E power socket + 0,50m of 6sq.mm cable	144.86

Please note, orders placed from 08/20/2024 will be increased by 20%

Prices are in Euros and fixed for the duration of the event - VAT excluded

## IT networks – LAN

To connect multiple devices together (PCs, printers, etc.), you will need a Local Area Network (LAN), by which each device is connected to a LAN access point. By adding an Ethernet connection, a LAN can also be used to share internet access.

ORDER with the venue VIPARIS > <https://www.viparisstore.com/en/#>



Document updated on March 30, 2024 - Informations are subject to change at any time

Pro4events, 3-17 chemin du Lanfonnet – 74320 Sevrier – France

e-mail [info@pro4events.com](mailto:info@pro4events.com) / [www.cigre-exhibition.com](http://www.cigre-exhibition.com)

# CLEANING

Included in the exhibitors' package

Paris  
Session 2024



GENERAL CLEANING is included in your package

- + cleaning of your stand after the building up
- + cleaning of your stand every day
- = carpet cleaning and emptied garbage cans.

WASTE REMOVAL **ORDER on VIPARIS store > <https://www.viparisstore.com/en/#>**

Reference	Description	Price in € excl. taxes
83020_PCP	Carpet removal (price per sq.m.)	1.22
82981_PCP	Removal of booth material ( on filmed wooden palet )	257.05



Please note, orders placed from 08/20/2024 will be increased by 20%

# CATERING

at your stand or in a meeting room

Paris  
Session 2024



Exhibitors can order catering service at the stand or in a meeting room  
(It is not allowed to prepare food at the stand)

**CATALOGUE RIEM BECKER > [CLICK HERE](#)**

**ORDER FORM > [CLICK HERE](#)**

Contacts :

Sébastien MANES [sebastien.manes@riembecker.fr](mailto:sebastien.manes@riembecker.fr) (+ 33 (0)1 86 64 14 46)

Ava MARZOLF [ava.marzolf@riembecker.fr](mailto:ava.marzolf@riembecker.fr) (+33 (0)6 22 89 16 78)

## For your information, on the exhibition floor :

Coffee breaks open to all > 9:30 -11h00 am + 3:00-5:00 pm (Levels 1,2,3)

Lunch bars (snacks, salads all day and every day)

Inside & outside the Congress Center, you can access to restaurants and a supermarket.

# HOSTESS

Paris  
Session 2024



## ORDER FROM DECIBELLES

Contact : Ana Calpe del Arco

e-mail : ana@deci-belles.com - Tel. +33 (0)1 40 60 11 28

HOSTESS : 192€ (8 hours) + 14.5€ MEAL & TRANSPORT

BARMAN : 192 € (8 hours) + 14.5 € MEAL & TRANSPORT

INTERPRETER : 224 € (8 hours) + 14.5 € MEAL & TRANSPORT

Deadline : 20 August 2024

Prices are in Euros and fixed for the duration of the event - VAT excluded

[DOWNLOAD THE ORDER FORM HERE](#)

# SECURITY GUARDS at your stand

Paris  
Session 2024



## ORDER FROM

Contact : Cédric Guerin

e-mail : cedric.guerin@guardevents.com - Tel. +33 (0)1 56 08 01 39

12 hours shift = 365,00 €

Additional hours = 46,00 €

Deadline : 20 August 2024

Prices are in Euros and fixed for the duration of the event - VAT excluded

[DOWNLOAD THE ORDER FORM HERE](#)

Document updated on March 30, 2024 - Informations are subject to change at any time

Pro4events, 3-17 chemin du Lanfonnet – 74320 Sevrier – France

e-mail [info@pro4events.com](mailto:info@pro4events.com) / [www.cigre-exhibition.com](http://www.cigre-exhibition.com)



# FLORAL DECORATION

Exotic or tropical plants, dwarf shrubs, arum lilies, citrus fruits, decorative foliage  
bouquets, dried flowers  
Fruit basket, flower arrangements

Paris  
Session 2024



ORDER on VIPARIS store > <https://www.viparisstore.com/en/#>



## PLANTS

Reference	Description	Price in € excl. taxes
GY142400_VIP	Planter with ficus arrangement (height 200cm)	172.50
GY146000_VIP	Planter with thatch palm (height 200cm)	172.50
GY182357_VIP	Planter with laurel ball tree (height 200cm)	128.75
GY123260_VIP	Wicker planter with kentia (height 200cm)	128.75
GY182356_VIP	Planter with ficus (height 200cm)	128.75
GY123250_VIP	Citrus plant (height 200cm)	225.00
GY1811018_VIP	Zamioculcas (height 160cm)	162.50
GY1811019_VIP	Planter with Orchid (height 110cm)	187.50
GY1811020_VIP	Dracaena Maginata (height 180cm)	125.00
GY1811021_VIP	Spatiphyllum (height 180cm)	162.50
GY1811022_VIP	Potted Spatiphyllum (height 120cm)	115.00
GY145700_VIP	Pyramid-shaped Laurel tree (height 200cm)	192.50
GY145800_VIP	Boxwood ball (height 90cm)	192.50
GY1811023_VIP	Potted Phormium (height 120cm)	137.50
GY182351_VIP	Bonsai ficus (height 150cm)	182.50

Please note, orders placed from 08/20/2024 will be increased by 20%

Prices are in Euros and fixed for the duration of the event - VAT excluded

AND MUCH MORE to see on VIPARIS STORE > <https://www.viparisstore.com/en/#>

Document updated on March 30, 2024 - Informations are subject to change at any time

Pro4events, 3-17 chemin du Lanfonnet – 74320 Sevrier – France

e-mail [info@pro4events.com](mailto:info@pro4events.com) / [www.cigre-exhibition.com](http://www.cigre-exhibition.com)

# BADGE READER

SCAN the QR code on Delegates, Visitors' badges to get their contact

Paris  
Session 2024



**Two (2) products are included in your package (no extra charge – provided by LENI company) :**

1/ 1 Kliposreader > it's a badge reader with the license pre-installed.

2/ 1 Kliposleads license that can be downloaded to your own **smartphone**.

It is activated with an activation code provided by LENI company: 1 activation code per smartphone.



The badge reader has to be collected from Saturday, August 24, from 9 am, at the Exhibitors Technical Services (LENI's desk) on Level 1 and returned on site at the end of the Congress on Friday 30 August at the same desk.

You must leave a deposit of 400 € per badge reader – Mandatory  
(bank footprint or French cheque - no Amex - no cash)

**The license can be installed on your smartphone as soon as you get the activation code from LENI company.**

Note that the activation code will not be available before August 24, 2024. Contact : [lecteurs@leni.fr](mailto:lecteurs@leni.fr)

**If you want to order more licenses :** 1 more license = **320 euros** (VAT excl.) > contact : [info@pro4events.com](mailto:info@pro4events.com)

**If you want to order a Bluetooth printer :** Price = **84 euros** (VAT excl.)

**[CLICK HERE TO SEE THE ORDER FORM](#) for the printer**

Contact : [lecteurs@leni.fr](mailto:lecteurs@leni.fr)



The Excel file of the contacts scanned during the Congress will be available on your badge reader area via your exhibitor space on your platform on line (after the Congress).

Technical information from LENI company on > <https://www.cigre-exhibition.com/wp-content/uploads/sites/1/Klipso-leads-DECK-EN-200422.pdf> [[cigre-exhibition.com](http://www.cigre-exhibition.com)]

Document updated on March 30, 2024 - Informations are subject to change at any time

Pro4events, 3-17 chemin du Lanfonnet – 74320 Sevrier – France

e-mail [info@pro4events.com](mailto:info@pro4events.com) / [www.cigre-exhibition.com](http://www.cigre-exhibition.com)

# TECHNICAL ASSISTANCE

## on site

### ON SITE TECHNICAL SERVICES FOR EXHIBITORS

Welcome desk to assist Exhibitors with power on stand, delivery of furniture, shell stands, premium stands, delivery & handling by ESI, ... pick up of your badge reader with LENI...

Location : on LEVEL 1

From Saturday 24 August (8 am) to Monday 26 August (2 pm)

#### Technical services opening hours :

Saturday 24 August : 8 am > 6 pm

Sunday 25 August : 8 am > 6 pm

Monday 26 August : 8 am > 2 pm

Orders have to be sent to Pro4events before the event > Deadline 15 April 2024.

If any questions, please send a mail to [info@pro4events.com](mailto:info@pro4events.com) / [marion.caumont@pro4events.com](mailto:marion.caumont@pro4events.com)

# GENERAL SECURITY

Paris  
Session 2024



**Security** : From **SUNDAY 25 August** to **FRIDAY 30 August**, each attendee will be checked by SECURITY at level 0 (street level)

## EXPECT LONGER DELAYS TO ACCESS THE SESSION

To ensure security during your stay at the Palais des Congrès in Paris, we have increased the number of agents during the Session, in addition to webcams.

Recommendations :

- . Avoid bringing suitcases to the Session: we have reduced the size of storage,
- . Remember to collect your items at the cloakroom on the same day during opening hours,
- . Security agents will apply the access control policy, kindly follow their instructions,
- . Report all suspicious objects or behaviour to security agents or to the police,
- . Do not accept to keep any item for someone else,
- . Do not allow items to pile up (cardboard boxes, pallets, bags etc.),
- . In case of emergency – call the police on **17** (or 197).

*Security is a collective responsibility. We thank you in advance for your help and understanding.*

**Safety measures:** Health and safety are our TOP priority. The venue, VIPARIS, has been accredited with the label « **Safe V Events** » from an independent authority.

All the necessary health measures are taken to ensure the highest standards during the Session : **Disinfection** of rooms, common areas, surfaces, equipment, lifts at all times, hand sanitiser available, air recycling, **Medical Center** with dedicated medical staff on level 3 (room 335).

**Environment** : with our partners, we aim at reducing our environmental footprint and sharing best practices.

Document updated on March 30, 2024 - Informations are subject to change at any time

Pro4events, 3-17 chemin du Lanfonnet – 74320 Sevrier – France  
e-mail [info@pro4events.com](mailto:info@pro4events.com) / [www.cigre-exhibition.com](http://www.cigre-exhibition.com)

## INSURANCE

Paris  
Session 2024



Badge readers, mobile phones, computers left unattended are not covered by the insurance.

**>> Please do not to leave any valuable overnight, even in a locked storage room or in a locked cabinet.**

[CLICK HERE](#) to get more information about guarantees & exclusions

## VAT REFUND

**TEVEA INTERNATIONAL** 29-31 rue Saint Augustin F 75002 PARIS, France  
[www.tevea-international.com](http://www.tevea-international.com)

[mail@tevea.fr](mailto:mail@tevea.fr)

[CLICK HERE](#) to get more information

Document updated on March 30, 2024 - Informations are subject to change at any time

Pro4events, 3-17 chemin du Lanfonnet – 74320 Sevrier – France  
e-mail [info@pro4events.com](mailto:info@pro4events.com) / [www.cigre-exhibition.com](http://www.cigre-exhibition.com)



# TO ATTEND CONFERENCES

not included with the Exhibitors' badge

[www.cigre.org](http://www.cigre.org)

**REGISTER HERE** > <https://session.cigre.org/registration.html>

opening of registrations mid-February 2023    **Early bird until 15 May, 2024**

**General programme on** <https://session.cigre.org/>



CIGRE 2022 - Non contractual pictures

**+ 8 600 attendees during CIGRE 2022 Session  
from 120 countries  
including 3 600 Delegates**



POSTERS

Over 160 working meetings,  
30 Study Committee sessions  
and around 800 technical papers  
focus on and discuss the association's  
16 fields of activities.

PHOTO GALLERY CIGRE 2022 > [CLICK HERE](#)

[Video CIGRE 2022](#)

#### Scopes of 16 Study Committees

- Rotating Electrical Machines
- Power transformers and reactors
- Transmission & distribution equipment
- Insulated Cables
- Overhead lines
- Substations and electrical installations
- DC systems and power electronics
- Protection and Automation
- Power system development and economics
- Power system operation and control
- Power system environmental performance
- Power system technical performance
- Electricity markets and regulation
- Active distribution systems and Distributed energy resources
- Materials and emerging test techniques
- Information systems and telecommunication

Document updated on March 30, 2024 - Informations are subject to change at any time

Pro4events, 3-17 chemin du Lanfonnet – 74320 Sevrier – France

e-mail [info@pro4events.com](mailto:info@pro4events.com) / [www.cigre-exhibition.com](http://www.cigre-exhibition.com)



**TECHNICAL EXHIBITION August 25 > 30, 2024**

Palais des Congrès, Paris

[www.cigre-exhibition.com](http://www.cigre-exhibition.com)

Electricity, Furniture, TV's & more services ORDER FORM

for exhibitors only

**Deadline 15 April, 2024**

To send to [marion.caumont@pro4events.com](mailto:marion.caumont@pro4events.com) / copy to [info@pro4events.com](mailto:info@pro4events.com)

It is not possible to cancel orders & invoices after 10 August, 2024 > **100% of the amount invoiced is due**

There will be a surcharge of **20 %** for orders placed after **20 August, 2024**

Company Order form n°/ PO

Date of order

Company name

Stand number /  
Number of sqm

Booth representative  
name

E-mail

Telephone

Address

European VAT Number



.../...

**“Ready to Exhibit” Package ORDER FORM**  
**ELECTRICITY (mandatory) + FURNITURE + TV LED SCREEN (if needed) & more services**  
**ONLY 1 SUPPLIER PRO4EVENTS ONLY 1 INVOICE ALL IN ONE !**  
**+ CUSTOMISED SERVICE**  
 Pro4events team takes care of your orders, replies to your technical questions, and gives you feedback

**READY TO EXHIBIT PACKAGE** Your company name \_\_\_\_\_

Item code	Description	QUANTITY	UNIT PRICE <small>VAT excl.</small>	TOTAL AMOUNT <small>VAT excl.</small>
<b>Electricity</b> Power supply for the stand <b>mandatory to order &gt; see prices on page 46</b>				
For example >> ..... .....	3 kw limited period of power supply = 415 euros or 3 kw 24h/24h power supply = 545 euros  .....  Due to technical reasons, you will not be able to ask for more Kw power during the Event - <b>Please, draw the location of the electrical panel on the floor plan below</b>	<b>NUMBER OF KW</b>  .....	.....	.....
<b>Furniture</b> Chairs, Tables, Sofas, Desks, Counters, Fridge, Coffee machine, Water fountains, brochure displays ... > see prices on page 48 and on the catalogue on line <a href="https://camerus.com/en/salon/cigre-2024/">https://camerus.com/en/salon/cigre-2024/</a>				
Reference :..... ..... ..... ..... ..... ..... .....	..... ..... ..... ..... ..... ..... .....	..... ..... ..... ..... ..... ..... .....	..... ..... ..... ..... ..... ..... .....	..... ..... ..... ..... ..... ..... .....
<b>TV Led screen</b> All TV's are supported by a foot > see prices on page 48				
.....	<b>There is no offer for TV's mounted on a wall</b>	.....	.....	.....

Prices are fixed for the duration of the event  
 Installation of the electricity, furniture, TV's on the stand is included in the price

**MORE SERVICES**  
 with Pro4events

<b>Formule + stands</b> order a <b>STORAGE ROOM</b> > information on page 49				
	Storage room 1 m x 1 m .....	.....	210 euros	.....
	Storage room 1 m x 2 m .....	.....	250 euros	.....
	Premium stands have already a storage room included in the premium package Please, draw the location of the storage room on the floor plan below			
<b>Premium stands</b> order 3 shelves & wardrobe inside the Storage Room > information on page 49				
	3 shelves & wardrobe.....	.....	64 euros	.....

.../...

Item code	Description	QUANTITY	UNIT PRICE VAT excl.	TOTAL AMOUNT VAT excl.
-----------	-------------	----------	-------------------------	---------------------------

Cover the pillars on your stand with advertising panels > increase your visibility > see page 29				
	MODULAR PANELS without signage.....	.....	115 euros	.....
	MODULAR PANELS with signage.....	.....	395 euros	.....
	WOOD PANELS without signage.....	.....	263 euros	.....
	WOOD PANELS with signage.....	.....	543 euros	.....
by CREATIFS > <a href="mailto:cigre.exposants@creatifs.fr">cigre.exposants@creatifs.fr</a>				

Total amount VAT excl./ Total HT	€
Services fee : + 15%	€
VAT / TVA (20%) no VAT for foreign companies	€
Total amount VAT incl. Total TTC (€)	€

An invoice will be issued shortly

Please note, orders placed from 20 August 2024 will be increased by 20%

For all questions on orders contact > [marion.caumont@pro4events.com](mailto:marion.caumont@pro4events.com) / copy to [info@pro4events.com](mailto:info@pro4events.com)

**IMPORTANT : fill in the floor plan below (on page 66)**

COMPANY : .....

Name : .....

Position : .....

E-Mail : .....

Authorized signatory :

Date & Stamp :

## Additional services to be ordered separately

### **UPGRADE to a Premium Stand** (More information page 31)

If your company ordered a BASIC STAND (raw space), upgrade for **500 euros** / sq.m.

If your company ordered a FORMULE + Shell stand, upgrade for **300 euros** / sq.m.

> complete the **ORDER FORM CLICK HERE** (<https://www.cigre-exhibition.com/wp-content/uploads/sites/1/order-form-to-upgrade-to-a-premium-stand.pdf>) + send a mail to [info@pro4events.com](mailto:info@pro4events.com)

**RIGGING STRUCTURES (suspension points)** More information on page 50 **DOWNLOAD THE FORM HERE**

**OFFICE EQUIPMENT** (printer, computers, video projector, electrical equipment, ....) More information pages 52-53

**FLORAL DECORATION** (page 56)

**WASTE REMOVAL** (page 56)

> ORDER directly on VIPARIS STORE <https://www.viparisstore.com/en/#> , copy to [info@pro4events.com](mailto:info@pro4events.com)

**CATERING** for food & beverage > contact RIEM BECKER More information page 54

Sebastien Manes > [sebastien.manes@riembecker.fr](mailto:sebastien.manes@riembecker.fr) + 33 (0)1 86 64 14 46

**HOSTESS** > contact DECIBELLES **DOWNLOAD THE FORM HERE**

Ana Calpe del Arco > [ana@deci-belles.com](mailto:ana@deci-belles.com) - Tel. +33 (0)1 40 60 11 28

More information page 55 – send a copy to [info@pro4events.com](mailto:info@pro4events.com)

**GUARDS** for the security of the stand > contact GUARD EVENTS **DOWNLOAD THE FORM HERE**

Cédric Guerin > [cedric.guerin@guardevents.com](mailto:cedric.guerin@guardevents.com) - Tel. +33 (0)1 56 08 01 39

More information page 55 – send a copy to [info@pro4events.com](mailto:info@pro4events.com)

**1 BADGE READER + 1 LICENSE** to be downloaded on your smartphone (included in your package) > If you need more licenses, please contact [info@pro4events.com](mailto:info@pro4events.com)



**Plan and technical information CIGRE 2024** mandatory for ALL STANDS

BOOTH NUMBER	
Company name	
Booth representative	
Mail address	
Telephone	

Does your stand have a floor ?  *yes* /  *no*

Use the following symbols to draw your stand and indicate the services you want to order :

———— Closed side

.-.-.-.- Open side

It is mandatory to complete the floor plan with your order and return it to  
[marion.caumont@pro4events.com](mailto:marion.caumont@pro4events.com)  
[info@pro4events.com](mailto:info@pro4events.com)

**E** Electrical panel (mandatory to order)

Leave an access to the electrical panel during the event  
 if you have a storage room, the electrical panel will be inside the storage room

**SR** storage room for Formule + stands (if needed)

storage room already included in the premium package

**@** wired Internet (position of the cable) order with VIPARIS <https://www.viparisstore.com/en/#>

Wifi is included in the Exhibitors' package

**T** Telephone (if needed) order with VIPARIS <https://www.viparisstore.com/en/#>

**PRO4EVENTS**  
PERFORMANCE FOR YOUR EXHIBITIONS

**If you want to order slings** > indicate the exact location, height, weight per sling and contact VIPARIS [contact@e-viparisstore.com](mailto:contact@e-viparisstore.com) [CLICK HERE TO SEE THE VIPARIS FORM & PRICE](#)

**DRAW YOUR STAND** with or without options

**COMPANY NAME :**

**STAND NUMBER :**



>> 1 cm corresponds to 1 m

Size of your stand : ..... m X .....m

	1	2	3	4	5	6	7	8	9	10	11	12
1												
2												
3												
4												
5												
6												
7												
8												
9												
10												

Do not forget to position your stand (aisle, nearby stand...)

*If the final location of internet cables & electrical panel, storage room, differs from that previously confirmed on this plan, you will be invoiced for the modification.*

Document subject to changes - contact : [info@pro4events.com](mailto:info@pro4events.com)





**TECHNICAL EXHIBITION August 25 > 30, 2024**

Palais des Congrès, Paris

[www.cigre-exhibition.com](http://www.cigre-exhibition.com)

FIRST COME  
FIRST SERVED

**ORDER FORM Sponsorship offers**

for exhibitors only

**Deadline 15 April, 2024**

To send to [sandrine.huchez@pro4events.com](mailto:sandrine.huchez@pro4events.com) / [marion.caumont@pro4events.com](mailto:marion.caumont@pro4events.com) / [info@pro4events.com](mailto:info@pro4events.com)

Company Order form n° / PO

Date of order

Company name

Stand number /  
Number of sqm

Booth representative  
name

E-mail

Telephone

Address

European VAT Number

## Exclusive Sponsorship

see our offers pages 16 > 22

Your company name \_\_\_\_\_

<b>DIAMOND (only 1 Sponsor)</b> first come, first served (description pages 16 > 22)	Quantity	Unit price (euros)	Total Amount
<b>OFFICIAL SPONSOR of the Welcome COCKTAIL RECEPTION</b> on the 3 levels, inside the exhibition on Sunday 25 August (around 16:30 pm to 7:30 pm, just after the Opening Ceremony) + 3 000 attendees > included in the package : your company logo printed on 9000 lanyards !!	Exclusive sponsor	65 000 € <small>or you may want to share the cost with another sponsor</small>	

<b>PLATINUM (only 1 Sponsor)</b> first come, first served (description pages 16 > 22)	Quantity	Unit price (euros)	Total Amount
<b>OFFICIAL SPONSOR of the CIGRE COCKTAIL DINER ("Soirée")</b> at the <u>Musée des Arts Forains</u> on Thursday 29 August (from around 7:00 pm) 2 400 delegates	Exclusive sponsor	42 500 €	

<b>GOLD 1 (only 1 Sponsor)</b> first come, first served (description pages 16 > 22)	Quantity	Unit price (euros)	Total Amount
<b>OFFICIAL SPONSOR of the WOMEN IN ENERGY Event (WIE)</b> at the Palais des Congrès on Thursday 29 August (11:30 am to 3:00 pm) 250 attendees	Exclusive sponsor	18 000 €	

<b>GOLD 2 (only 1 Sponsor)</b> first come, first served (description pages 16 > 22)	Quantity	Unit price (euros)	Total Amount
<b>OFFICIAL SPONSOR of the NGN Event (Young Engineers)</b> at the Palais des Congrès on Wednesday 28 August (11:30 am to 3:00 pm) 250 attendees	Exclusive sponsor	18 000 €	

**Reminder : all sponsorship levels DIAMOND, PLATINUM, GOLD 1 or GOLD 2 will include the following:**

- + 1 advertising page displayed on CIGRE TV
- + Your company logo displayed in ALL the coffee breaks and lunch areas

## More Sponsorship Opportunities :

First come, First served

Your company name \_\_\_\_\_

<b>Speaking opportunity in the exhibition (offer 1)</b> first come, first served		Quantity	Unit price (euros)	Total Amount
<b>Present your company's services, products during 25 mns, at lunch time</b> In a dedicated conference open space : "The Experts Forum" on level 3 (open to all) Equipment : 1 monitor, 1 HDMI cable, microphones, desks & chairs <i>The promotion of the speech has to be done by the Exhibitor</i>			<b>4 900 €</b> 1 slot of 25 mns	

<b>CHOOSE YOUR SLOT(s)</b> 1 SLOT = 25 mns speech	MONDAY 26 August 2024		TUESDAY 27 August 2024		WEDNESDAY 28 August 2024		THURSDAY 29 August 2024		FRIDAY 30 August 2024	
TIMES	Price	SLOT	Price	SLOT	Price	SLOT	Price	SLOT	Price	SLOT
12:00 – 12:25	4 900 euros		4 900 euros		4 900 euros		4 900 euros		4 900 euros	
12:30 – 12:55	4 900 euros		4 900 euros		4 900 euros		4 900 euros		4 900 euros	
13:00 – 13:25	4 900 euros		4 900 euros		4 900 euros		4 900 euros		4 900 euros	
13:30 – 13:55	4 900 euros		4 900 euros		4 900 euros		4 900 euros		4 900 euros	
14:00 – 14:30	4 900 euros		4 900 euros		4 900 euros		4 900 euros		4 900 euros	

updated on 05 February 2024 – subject to changes

Your company name \_\_\_\_\_

<b>INTERVIEW ON CIGRE TV (offer 2)</b> first come, first served		Quantity	Unit price (euros)	Total Amount
<b>2 mns speech or interview to be played during the event on CIGRE TV</b> CIGRE TV channel will broadcast daily informative content during the Event (& in replay) Date, time, location to be confirmed before the event			<b>5 900 €</b> 1 slot of 2 mns	

<b>CHOOSE YOUR SLOT(s)</b> 1 SLOT = 2 mns speech / interview	MONDAY 26 August 2024		TUESDAY 27 August 2024		WEDNESDAY 28 August 2024		THURSDAY 29 August 2024		FRIDAY 30 August 2024	
	Price	SLOT	Price	SLOT	Price	SLOT	Price	SLOT	Price	SLOT
2 mns broadcasted in the morning	5 900 euros		5 900 euros		5 900 euros		5 900 euros		5 900 euros	
2 mns broadcasted in the morning	5 900 euros		5 900 euros		5 900 euros		5 900 euros		5 900 euros	
2 mns broadcasted in the afternoon	5 900 euros		5 900 euros		5 900 euros		5 900 euros		5 900 euros	
2 mns broadcasted in the afternoon	5 900 euros		5 900 euros		5 900 euros		5 900 euros		5 900 euros	

updated on 05 February 2024 – subject to changes

Time slot registration shall not become effective unless a written confirmation is sent to exhibitor by Pro4events  
 (info@pro4events.com)

Your company name \_\_\_\_\_

<b>DISPLAY YOUR VIDEO IN CONFERENCE ROOMS (offer 3)</b> first come, first served (Targeted audience : + 3 500 Delegates)	Quantity	Unit price (euros)	Total Amount
<b>Your advertising video MP4 (limited to 30 seconds) played alternately with 5 other sponsors</b> <b>In CONFERENCE ROOMS</b> : Opening panel, GDM, Tutorials, Workshops.. During 1 day or during 5 days (& in replay) for Delegates During conference breaks (up to 8 breaks/day) <i>To view your advertising video you need to register as a Delegate</i>		6 500 € 1 video played 1 day OR 14 900 € 1 video played 5 days  ONLY 5 SPONSORS	

Limited to 5 sponsors	MONDAY 26 August 2024	TUESDAY 27 August 2024	WEDNESDAY 28 August 2024	THURSDAY 29 August 2024	FRIDAY 30 August 2024
up to 8 breaks each day >> <b>before or after the conferences when it's possible &amp; during conference breaks</b>  Breaks = approximately 10 mns 1 same video can be played around 4 times during a 10 mns break	in 3 conference rooms  Opening Panel Tutorials Workshops 2000 Delegates	in 7 conference rooms  GDM Tutorials Workshops 1800 Delegates	in 7 conference rooms  GDM Tutorials Workshops 1800 Delegates	in 5 conference rooms  GDM Tutorials Workshops 1800 Delegates	in 5 conference rooms  GDM Workshops 1800 Delegates

CHOOSE YOUR SLOT(s) 1 SLOT = 1 video played 1 day	Price	SLOT	Price	SLOT	Price	SLOT	Price	SLOT	Price	SLOT
	6 500 euros		6 500 euros		6 500 euros		6 500 euros		6 500 euros	
<b>Special price for 1 video played 5 days = 14 900 euros</b>										

[General Programme CIGRE 2024 on www.cigre.org/GB/events/paris-session-2024](http://www.cigre.org/GB/events/paris-session-2024)

Your company name \_\_\_\_\_

<b>DISPLAY YOUR VIDEO INSIDE THE CONGRESS CENTER (offer 4)</b> first come, first served	Quantity	Unit price (euros)	Total Amount
<b>Your advertising video MP4 (limited to 30 seconds) played alternately with 1 other sponsor</b> <b>on 24 digital panels 75' - during 9 days (every minute)</b> <b>HIGH VISIBILITY</b> > in the New Welcome area on level 0, in the corridors of the Hyatt Hotel, in front of the main amphitheater (where the Opening Ceremony takes place),...		26 800 € 1 video played on 24 digital panels during 9 days  ONLY 2 SPONSORS	

<b>ADVERTISING PAGE IN THE GUIDEBOOK (offer 5)</b> first come, first served	Quantity	Unit price (euros)	Total Amount
<b>Your advertising page printed in the Session Guidebook</b> =8500 printed catalogues distributed during the Session to ALL			
Back cover = 7 850 €	<b>BOOKED</b>	.....	
inside front cover = 4 500 €	.....	.....	
inside back cover = 4 000 €	.....	.....	
Full page 4 colors = 1 600 €	.....	.....	
½ page = 1 100 €	.....	.....	



Your company name \_\_\_\_\_

EXCLUSIVE BANNER ON THE CIGRE 2024 APP (offer 6) first come, first served	Quantity	Unit price (euros)	Total Amount
+ 11 000 mobile app downloads last Session 2022 Only 1 sponsor		17 500 € EXCLUSIVE SPONSOR	

OUTDOOR LOGO ON THE MAIN FAÇADE OF THE CONGRESS CENTER (offer 7) first come, first served	Quantity	Unit price (euros)	Total Amount
<b>HIGH VISIBILITY</b> Announcement of the CIGRE Session with the CIGRE logo + your logo Panel 13m long x 10m long on the main facade of the Congress Center Displayed during 9 days		9 850 € EXCLUSIVE SPONSOR	

**SOLD**

Time slot registration shall not become effective unless a written confirmation is sent to exhibitor by Pro4events (info@pro4events.com)



## ORDER FORM Sponsorship offers

<b>Total amount VAT excl./ Total HT</b>	€
<b>VAT / TVA (20%)</b> <i>no VAT for foreign companies</i>	€
<b>Total amount VAT incl. Total TTC (€)</b>	€

Order form to send to [marion.caumont@pro4events.com](mailto:marion.caumont@pro4events.com) / [info@pro4events.com](mailto:info@pro4events.com)

An invoice will be issued once availability is confirmed

I have read and agreed to the rules and regulations of the Sponsorship offer CIGRE 2024 next page.

**COMPANY :**.....

**Name :**.....

**Position :**.....

**E-Mail :** .....

**Authorized signatory :**

**Date & Stamp :**

## RULES Sponsorship offers CIGRE 2024

**REGISTRATION : First come, First served.** Time slot registration shall not become effective unless a written confirmation is sent to the Exhibition Manager by Pro4events ([info@pro4events.com](mailto:info@pro4events.com))

**PROMOTION of your speech / video :** Exhibitors make their **OWN promotion** of their speech, interview or advertising video on their own stand, website, social networks, with the logo CIGRE. Exhibitors shall not advertise any other company or contractor.

**Subject of speech/videos :** Each speech, interview or advertising video **must comply with CIGRE domains of work** > (<https://www.cigre.org/GB/knowledge-programme/our-16-study-committees-and-domains-of-work>).

**CIGRE LOGO to be inserted** in your videos > <https://marketingresources.cigre.org/GB/brand-materials/logos-and-guidelines>

**The language used in speeches, videos and in documents must be only English.**

> Send a mail with the name of the Speaker & contact (mail & tel.) + a text explaining the subject & content of what the Speaker would like to talk about, during the speech / interview, videos > before May 30, 2024 to [sandrine.huchez@pro4events.com](mailto:sandrine.huchez@pro4events.com)

Suggestions for your speech, interviews : exhibitors can speak about products, novelties, news related to CIGRE activities...

No external links are allowed in videos, no URL address, no tracking.

**It is not possible to ask for any modifications of slot, speaker, speech, advertising video, after June 15, 2024.**

**Access to your video / interview :** To view your video displayed in the conference rooms, you need to get a Delegate pass Register before the Session on > <https://session.cigre.org/registration.html>

To view your interview on CIGRE TV in replay, click on CIGRE website on <https://session.cigre.org/>

### IN THE EXHIBITION HALLS :

**Noise :** The maximum level of noise is 65 dB > Speakers must use microphones and attendees must use headphones.

**Products displayed :** Only small devices & products for display are accepted. No flying objects.

**No flyers** or advertising material is allowed in the Exhibition Halls.

**Exhibitors must comply with the General Rules on** <http://www.cigre-exhibition.com/form/cgv/>

CONTACT : [sandrine.huchez@pro4events.com](mailto:sandrine.huchez@pro4events.com) / [info@pro4events.com](mailto:info@pro4events.com)

[www.cigre-exhibition.com](http://www.cigre-exhibition.com)

## ORDER FORM “Ready to use” ROOM

For rental (for exhibitors only) First come, First served

Deadline 15 April, 2024



Company Order form n°/ PO

Date of order

Company name

Stand number

Booth representative

E-mail

Telephone

Address

European VAT Number

**Room for rental “ready to use”** > see the offer page 23 Rental from Monday 26 to Friday 30 August 2024

DESCRIPTION	QUANTITY	UNIT PRICE VAT excl.	TOTAL AMOUNT
FOR a 12 sqm room welcoming up to 6 persons <b>Package 1</b> including : 4 walls 1 door & lock 1 window with your LOGO on it Carpet on floor Power supply & sockets Lights Wireless HD Wifi + Basic chairs (up to 6 chairs) + Tables (if meeting room style) or 1 desk (if theatre style) + 1 TV screen with HDMI cable		4 000 euros  for 5 days	
FOR a 24 sqm room welcoming up to 10 persons (meeting room style) OR welcoming up to 14 persons (theatre room style) <b>Package 2</b> Including : 4 walls 1 door & lock 1 window with your LOGO on it Carpet on floor Power supply & sockets Lights Wireless HD Wifi + Basic chairs (up to 10 or up to 14 chairs) + Tables (if meeting room style) or 1 desk (if theatre style) + 1 TV screen with HDMI cable		6 500 euros  for 5 days	

For more services : more audio-visual equipment, internet LAN, projectors, more furniture, cleaning, catering..., Pro4events Team helps you find a supplier > see our offer page 23

FIRST COME  
FIRST SERVED

TECHNICAL EXHIBITION August 25 > 30, 2024  
Palais des Congrès, Paris [www.cigre-exhibition.com](http://www.cigre-exhibition.com)

## ORDER FORM Room for Rental

<b>Total amount VAT excl./ Total HT</b>	€
<b>VAT / TVA (20%)</b> <i>no VAT for foreign companies</i>	€
<b>Total amount VAT incl. Total TTC (€)</b>	€

Order form to send to [marion.caumont@pro4events.com](mailto:marion.caumont@pro4events.com) / [info@pro4events.com](mailto:info@pro4events.com)

An invoice will be issued once availability is confirmed

I have read and agreed to the rules and regulations of the Rental room offer CIGRE 2024 next page.

**COMPANY :**.....

**Name :**.....

**Position :**.....

**E-Mail :** .....

**Authorized signatory :**

**Date & Stamp :**

## RULES Meeting Room for rental

Exhibitors renting a “Ready to use” Room :

- Shall not reduce the number of square meters already booked for the stand in the Exhibition,
- Shall not rent the room to another company,
- Shall not advertise any other company or contractor without the agreement of Pro4events,
- Shall keep the room clean. It is understood that the cleaning of the rented room is at the exhibitor (tenant) expense. Viparis is proposing cleaning service if needed,
- Noise: The maximum level of noise is 65 dB,
- No advertisement will be allowed on the outside walls of the room except the exhibitors' name,
- Pro4events is organizing General Security but is not responsible for any loss of items or damage.

We remind you that :

**Pro4events is choosing the location on the Exhibition floor, inside the Palais des Congrès.**

Registration shall not become effective unless a written confirmation is received by the Exhibitor (tenant) from Pro4events. (limited space).

Exhibitors shall also agree with the General rules & regulation on <http://www.cigre-exhibition.com/form/cgv/>

CONTACT : [sandrine.huchez@pro4events.com](mailto:sandrine.huchez@pro4events.com) / [info@pro4events.com](mailto:info@pro4events.com)

[www.cigre-exhibition.com](http://www.cigre-exhibition.com)



PAYMENT

**PRO4EVENTS will send to the Exhibition Manager an invoice after confirmation of the availabilities.**

Exhibitors can choose to pay directly by bank transfer or Credit Card :

Bank Address / adresse Banque Société Générale Agence ANNECY ROYALE 9B rue Royale 74009 ANNECY - France	Account / compte PRO4EVENTS SARL IBAN : FR76 3000 3030 7000 0206 0438 860 BIC address / SWIFT code : SOGEFRPP	For European countries : EU + Switzerland, Norway, Iceland and Lichtenstein Bank transfer SEPA only or fees will be charged to your company For all others countries : Bank transfer SHARE or fees will be charged to your company
---	--	---

SIRET : 480 934 660 00030 TVA / VAT Intracommunautaire : FR 93 480 934 660

PRO4EVENTS 3-17 chemin du Lanfonnet – 74320 Sevrier – France - [info@pro4events.com](mailto:info@pro4events.com) - [www.cigre-exhibition.com](http://www.cigre-exhibition.com)

**Authorization**

Payment by credit card (2 % additional fees)

Please complete and send back to david.flandin@pro4events.com ONLY

Cardholder Name			
Billing address			
Zip code			
City			
Country			
Credit card type	VISA	<input checked="" type="checkbox"/>	
	MASTERCARD	<input type="checkbox"/>	Tick the box

Credit card number (16 digit)	____ / ____ / ____ / ____
Expiration date (MM/YY)	__ / __
Card ident. number (3 last digits located on the back of the credit card)	__ __

Amount to charge	
------------------	--



**On the way to CIGRE 2024 ! Do not hesitate to contact us for any question.**

**TECHNICAL EXHIBITION** > [www.cigre-exhibition.com](http://www.cigre-exhibition.com)

David Flandin, General Manager > [david.flandin@pro4events.com](mailto:david.flandin@pro4events.com)

Sandrine Huchez > [sandrine.huchez@pro4events.com](mailto:sandrine.huchez@pro4events.com)  
Sponsorship Offers, Press, Job Center, orders...

Marion Caumont > [marion.caumont@pro4events.com](mailto:marion.caumont@pro4events.com)  
Orders, technics, floor plans, rooms reservation ...

Adil ELHOUMANI > [stand-approval@pro4events.com](mailto:stand-approval@pro4events.com)  
Approval of stand builders constructions

General mail : [info@pro4events.com](mailto:info@pro4events.com)

**CONFERENCE** > <https://session.cigre.org>

General programme on  
> <https://session.cigre.org/programme/technical-programme.html>

Paris  
Session 2024



Document subject to changes, updated on 30 March, 2024

Pro4events, 3-17 chemin du Lanfonnet – 74320 Sevrier – France  
e-mail [info@pro4events.com](mailto:info@pro4events.com) / [www.cigre-exhibition.com](http://www.cigre-exhibition.com)